

PEARL CYMBAL BOOM STAND / CYMBAL STAND BC-100S

Instruction Manual

Congratulations on your purchase!
To get optimum performance of your Cymbal Boom Stand,
please read this Instruction Manual before playing.

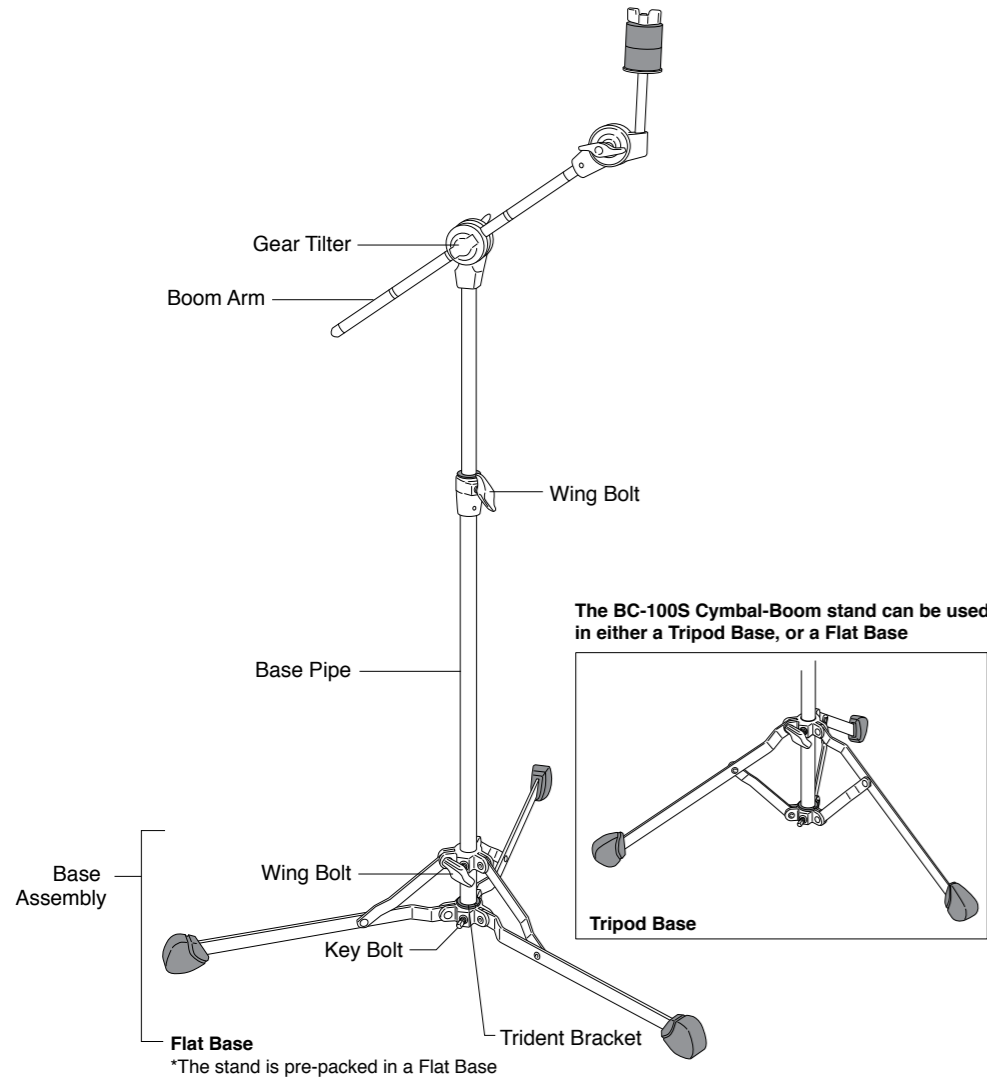

Assembling the Base (from Flat Base to Tripod Base)

Loosen the Wing Bolt and the Key bolt of the base, then, slide the legs off from the Base Pipe (Fig.1).

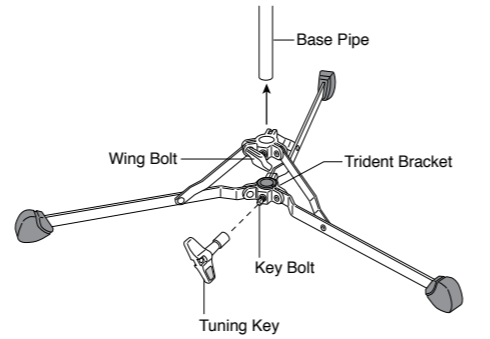

Fig. 1

Caution
Support the Base Pipe with one hand to prevent the stand from falling.

Turn the Base Assembly over from Flat Base to Tripod Base, and change the Wing Bolt and the Key Bolt so that the Key Bolt is always at the bottom (Fig.2).

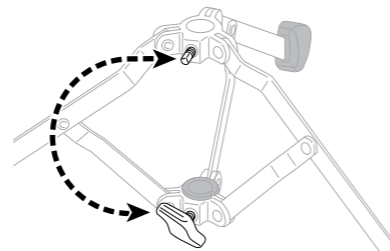

Fig. 2

Spread the legs and insert the Base Pipe. Make sure that the bottom of the pipe and the Trident Bracket are set flush, and tighten the Key Bolt and the Wing Bolt (Fig.3).

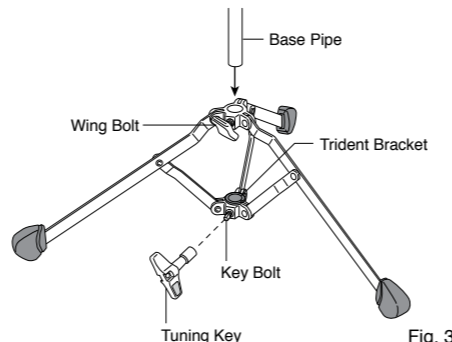

Fig. 3

Assembling the Base (from Tripod Base to Flat Base)

Loosen the Wing Bolt and the Key bolt of the base, then, slide the legs off from the Base Pipe (Fig.4).

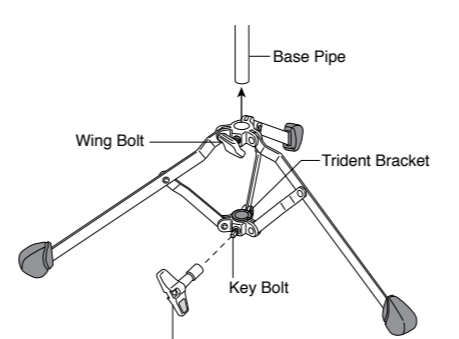

Fig. 4

Caution
Support the Base Pipe with one hand to prevent the stand from falling.

Turn the Base Assembly over from Tripod Base to Flat Base, and change the Wing Bolt and the Key Bolt so that the Key Bolt is always at the bottom (Fig.5).

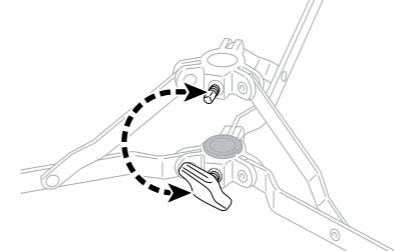

Fig. 5

Spread the legs and insert the Base Pipe. Make sure that the bottom of the pipe and the Trident Bracket are set flush, and tighten the Key Bolt and the Wing Bolt (Fig.6).

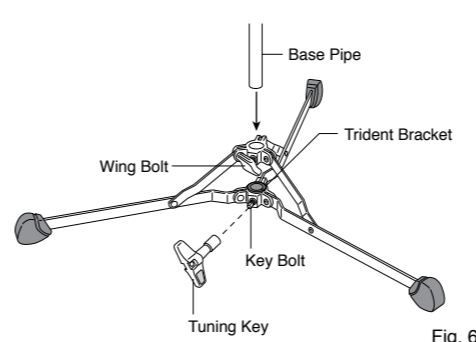
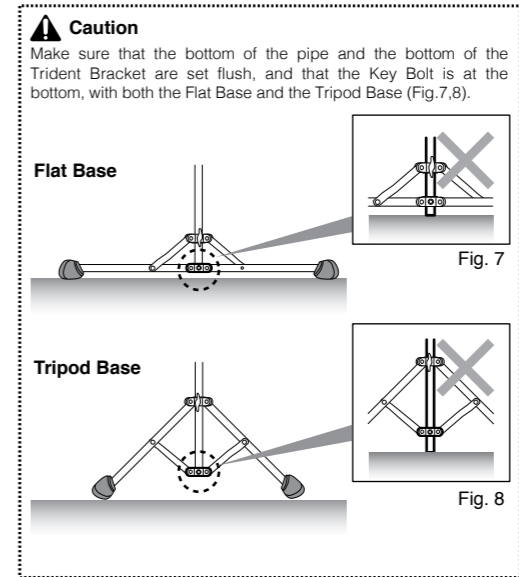

Fig. 6



Caution

- ◆ When making any adjustment, use one hand to support and make the adjustment while using your other hand to control the tension of the wing nut or wing bolt to prevent the stand from falling and pinching fingers that may be in the way.
- ◆ When folding the tripod legs, be careful not to pinch your fingers between the legs and the stand.
- ◆ When handling tubular hardware do not put your fingers into the tubes to prevent injury to your fingers.
- ◆ For optimal stability, orient one leg in the same direction as the boom.
- ◆ Do not tighten the bolts without the pipes inserted to prevent damage to the stand.
- ◆ Test the stability of the stand before using. If necessary, readjust the length of the boom, the direction of the boom, or weight of the load until the stand is sufficiently stable.

