

# PEARL DOUBLE PEDAL COMPLETE

## P-902 / P-902L P-901 (Double Pedal ASSEMBLY)

### INSTRUCTION MANUAL

Congratulations on your purchase!

For optimum performance and explanation of the features and adjustments of this pedal, please read this Instruction Manual before playing.

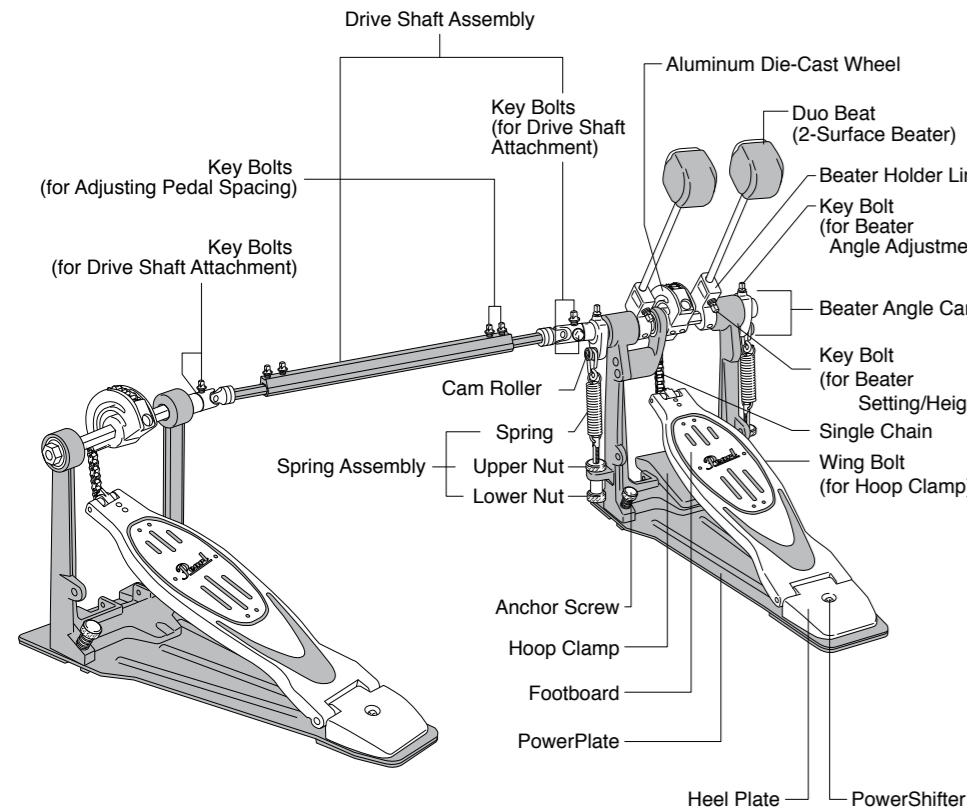

### BASIC SET-UP

1. Connect one end of the Drive Shaft Assembly to the short extension of the axle of the Secondary pedal as shown. (Fig. A)

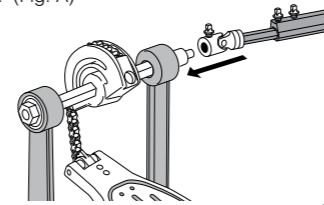

Fig. A

2. Connect the other end of the Drive Shaft Assembly to the short extension of the axle on the left side of the Primary pedal as shown. (Fig. B)

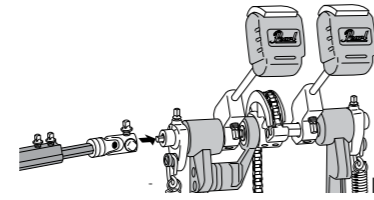
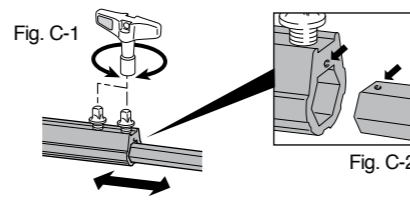

Fig. B

**Note:** You may need to rotate the Drive Shaft Assembly to bring the footboard of the Secondary (left) pedal to the proper playing height (angle) before attaching the Drive Shaft to the Primary pedal.

3. Loosen the Key Bolts on the Center Connecting Tube of the Drive Shaft. Adjust the distance between the Primary pedal and the Secondary pedal to your liking. Re-tighten the Key Bolts. (Fig. C-1)



**Note:** If the pedals are extended too far, the Drive Shaft will come apart. Reassemble the Drive Shaft with the dots aligned as shown in Fig. C-2.

### POWERSHIFTER

The P-902 is equipped with Pearl's exclusive PowerShifter function that changes the leverage of the footboard and thus the feel of your pedal. Please refer to the chart below to determine the position best suited to your playing style.

Position	Feel
A	"STRONG"
B	"NORMAL"
C	"LIGHT"

To change the position of the PowerShifter, loosen the Key Bolt in the Heel of the Footboard and move the Footboard to the desired position: A, B, or C. Prongs under the Heel fit into holes in the Power Plate and when properly aligned, the Heel will sit flush against the Power Plate. Re-tighten the Key Bolt to secure the Heel to the Power Plate.

**Note:** The Heel must be flush against the Power Plate or damage to the Pedal may result.

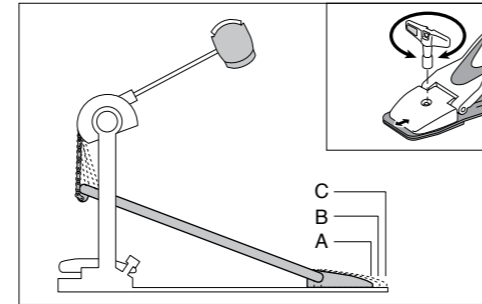

### DUO BEAT (2-Surface Beater)

The Duo Beat Beater features a Felt Surface (A) for a full, warm sound and a Plastic Surface (B) for a sharper, punchier sound. Use the side that best suits your playing style.



### BEATER SETTING

Locate the Beater Holder Link and Key Bolt. Insert the shaft of the Duo Beat into the Beater Holder Link and tighten the Key Bolt to secure the Beater at the desired height. Experiment with different beater heights to find the best combination of power and speed.

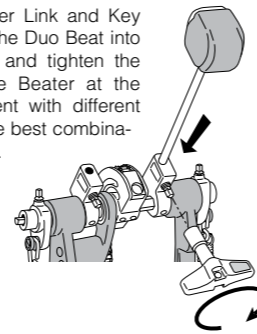

### BEATER ANGLE ADJUSTMENT

Depending on your preference, the beater can be positioned closer or further away from the bass drum head. This is accomplished by loosening the Key Bolt on the Beater Angle Cam and swinging the beater to the desired angle. Re-tighten the Key Bolt.

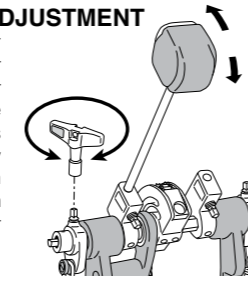

### SPRING TENSION ADJUSTMENT

To increase the tension of the spring, loosen the Upper Nut and tighten the Lower Nut until the desired tension is achieved. To decrease the tension, loosen the Lower Nut, tighten the Upper Nut until the desired tension is achieved. Once you're satisfied with the spring tension, tighten the Upper Nut securely to keep the spring tension from loosening while playing.

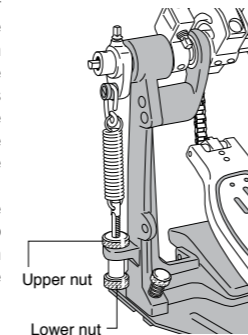

### ANCHOR SCREW

Turn the Anchor Screws clockwise to help prevent your pedals from sliding. Use a rug or carpet to protect floor surfaces.

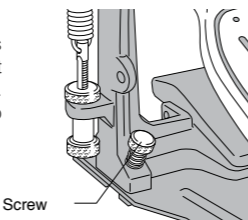

### HOOP CLAMP SYSTEM

Place the pedal on the bass drum hoop and square the pedal to the floor. Tighten the Wing Bolt to clamp the pedal firmly in place.

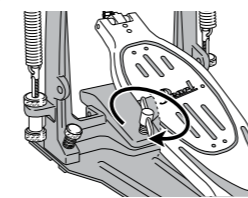

## THE P-901 ADD-ON PEDAL CONVERTS YOUR P-900 SINGLE PEDAL INTO A DOUBLE PEDAL.

The P-901 includes the following components:

1. Primary Pedal
2. Duo Beat Beater\*
3. Driveshaft Assembly

### Note

\*P-901 includes only one beater.

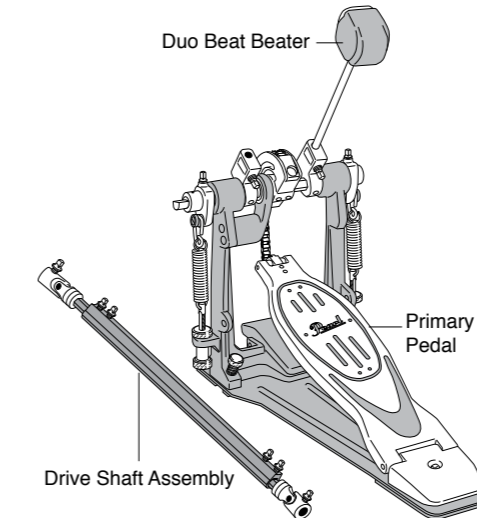

Your P-901 Add-On pedal will become the Primary (right) pedal and your P-900 single pedal will become the Secondary (left pedal) of the double pedal.

Before assembly please prepare your P-900 for use by following the steps below.

1. Remove the Key Bolt and the Duo Beat Beater from the Beater Holder Link as shown.
2. Loosen the Key Bolt on the Beater Angle Cam and remove the Beater Angle Cam.
3. Unscrew and remove the Lower Nut and remove the Spring Assembly as shown.

### Note

Keep the parts that you removed should you decide to convert your P-900 back into a single pedal.

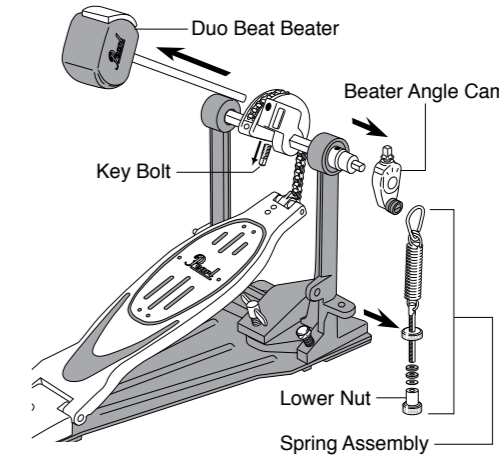

Your P-900 pedal is now ready to be used as the Secondary pedal and can be attached to the left side of the P-901 via the Drive Shaft Assembly. Please refer to the basic set-up instructions at the beginning of this manual to complete the assembly of your double pedal.

### Note

The P-901 only includes one beater. Please use the beater from your P-900 as the secondary beater on the Primary Pedal.

**CAUTION**

- ◆ Take care when handling or moving the fully assembled P-902/902L Twin Pedal to prevent damage to the Drive Shaft and its components.
- ◆ Periodically check all Allen Screws for tightness and tighten them with the provided Allen Wrenches as needed.
- ◆ Periodically apply lube to all moving parts such as the Chain, Cam Roller, Footboard Hinge, etc. for optimal speed and extended life of your pedal. Bearings should be lubricated with grease, not liquid oil.
- ◆ To maximize traction of the rubber mats underneath the PowerPlate, keep them clean and dust free using a damp cotton towel.

**Pearl**

<http://www.pearldrums.com>  
Products and specifications are subject to change without notice.  
Printed in China.  
-0902-