

A high-quality photograph of a Pearl drum set. The set includes a blue bass drum with a white front head, two blue toms, and a blue snare drum. The hardware is chrome. The Pearl logo is visible on the bass drum head and the toms. The background is dark, making the drums stand out.

Pearl[®]

2 0 2 4
GENERAL CATALOG



INSPIRATION AWAITS!

With nearly eight decades of legendary crafting history firmly cemented in the lives of countless drummers, 2024 sees Pearl advancing the drum set to unsurpassed heights. Our goal was to make the complete selection and performance aspect of drumming effortless and fuel the current of rhythmic creativity in a new generation of players. This would include an odyssey into the very foundations of drum making, from shell formation to mounting platforms, to eliminate stress and let each drum truly sing. The solution lies in reimagining the benefits of tom suspension systems on a new era of professionally catered percussion items, to showcase the sonic and visual identity of each drummer and bridge the gap between Player and Instrument.



MASTERWORKS
p. 3 - 10

Custom made in your personal selection of woods, edges, sizes, and veneers.

SHELL RECIPE
Individually tailored combination of Birch, Maple, Gumwood, and/or Mahogany.

SOUND
The tonal reality of your ultimate ideal, Masterworks literally sounds like every drum set you've ever dreamed of.



REFERENCE ONE
p. 11 - 12

The ultimate ideal of the modern hybrid drum concept, all components are independently engineered for the best tonality in every quadrant of the kit.

SHELL RECIPE
EvenPly Birch, Maple, and Mahogany hybrid.

SOUND
Expressive, wide range sonic boost with enhanced bottom-end.



CRYSTAL BEAT
p. 27 - 28

The original seamless Acrylic drum shell creates a striking visual and sonic showcase.

SHELL RECIPE
Seamless molded Acrylic
(Tom and Floor Tom: 6mm / Bass Drum: 7mm)

SOUND
Loud and immediate, delivers pummeling straight tone and yielding feel.



DECADE MAPLE
p. 29 - 30

Premium gear for the evolving drummer, featuring lacquered all Maple shells and pro-level elements.

SHELL RECIPE
EvenPly-Six, 5.4mm Maple

SOUND
Full maple tone with lively midrange and smooth sustain.



EXPORT
p. 31 - 32

The Best-Selling Drum Set of All Time gives the student drummer a strong beginning.

SHELL RECIPE
6-ply 7.5mm Poplar and Asian Mahogany hybrid

SOUND
Crisp attack with dark, formidable bottom-end vibrance.



MASTERS MAPLE / GUM
p. 15 - 16

Optimized for the recording studio; vital tone derived from the Masterworks: Studio shell recipe.

SHELL RECIPE
EvenPly-Six Maple (4-ply outer) and Gumwood (2-ply inner)

SOUND
Explosive midrange tonality with full low-end and precise decay.



MASTERS MAPLE
p. 17 - 18

Three decades of Masters excellence is reimagined with our history-making 6-ply Maple shell and a host of massive upgrades.

SHELL RECIPE
6-ply, 7.5mm Premium Maple.

SOUND
Attack and projection with smooth, full-bodied resonant attack.



MASTERS MAPLE PURE
p. 19 - 20

Pearl's original premium MMX shell formula delivers near-field resonance and sharp top-end attack for varied pro environments.

SHELL RECIPE
4-ply, 5mm Premium Maple w/4-ply Reinforcement Rings.

SOUND
Balance of powerful midrange and smooth resonant attack.



MIDTOWN
p. 33

An ultra-portable shell pack for full-sized play and powerful grooves in a small footprint.

SHELL RECIPE
6-ply 7.5mm Poplar

SOUND
Tight, responsive tonal bite with enough bottom to fill the pocket.



ROADSHOW
p. 34

A drum set package complete with everything needed to kickstart your rhythmic journey.

SHELL RECIPE
6-ply 7mm Poplar

SOUND
Piercing, open cut with the right amount of sub-bass rumble to keep you inspired.



PROFESSIONAL SERIES
p. 21 - 22

A gig-friendly workhorse derived from our classic MLX Series that's excellent for independent touring.

SHELL RECIPE
EvenPly-Six, 5.4mm North American Maple

SOUND
Equal parts Low/Mid/High frequency punch with smooth, extended decay.



SESSION STUDIO SELECT
p. 23 - 24

Radically unique Studio blend with pre-EQ'd warmth and cutting, articulate strike.

SHELL RECIPE
EvenPly-Six Birch (4-ply outer) and African Mahogany (2-ply inner)

SOUND
Deep, rich bass frequencies combined with top-end tonal drive.



PRESIDENT SERIES DELUXE
p. 25 - 26

Dark, dry vintage spread with the classically controlled "MJ Sound".

SHELL RECIPE
6-ply, 7.5mm Lauan.

SOUND
A slick, sonic locomotive of subdued, vintage punch with singular low-range overtone.

2024 GENERAL CATALOG

DRUM SETS	SNARE DRUMS	HARDWARE	PERCUSSION
3-10 Masterworks	37-40 Series Component	55-56 Demon XR	77 Percussion Artists
11-12 Reference One	41 Free Floating	57 Demon Drive	78 Signature Series
13-14 Masters Introduction	42 SensiTone Heritage Alloy	58 Demon Chain	79-80 Congas & Bongos
15-16 Masters Maple/Gum	43-44 Signature	59-60 Eliminator Redline	81-82 Travel (Congas, Bongos, Timbales)
17-18 Masters Maple	45 Hybrid Exotic	61-62 Eliminator Solo	81 Timbales
19-20 Masters Maple Pure	45 UltraCast	63-64 P930 / P932	82 Cowbells
21-22 Professional Series	45 Duoluxe	65-66 P530 / P830	83 Djembes
23-24 Session Studio Select	46 StaveCraft	67-68 Hi-Hat Stands	83-84 Ashiko Drum / Folkloric
25-26 President Series Deluxe	47 Modern Utility	69 Snare Stands	85-86 Cajons & Cajon Accessories
27-28 Crystal Beat	48 Effects	70 Drum Thrones	87 Handpans
29-30 Decade Maple	ELECTRONIC SERIES	71-72 Cymbal Stands	88 Tongue Drums
31-32 Export	49-50 e/MERGE	73-74 Racks	89 Rainsticks / Nut Shakers
33 Midtown	51 MIMIC PRO	75 Rack Accessories	90 Concert Percussion
33 Rocket Toms	52-54 malletSTATION	76 Tom Stands	91-92 Hand Percussion
33 Compact Traveler		76 Tom Arms	93 Percussion Stands
34 Roadshow / Roadshow Jr.			94 Bags & Holders
93-96 Replacement Parts	99-102 Pearl Artists	103-BACK Config. & Color Chart	106 Warranty Info



Completely Custom, Totally Handmade

HANDCRAFTED FOR GREATNESS

Masterworks is the realization of your ultimate drum set vision. Every aspect of the kit is curated by you and built to your exacting specifications.



EXPLORE. CREATE. INSPIRE.

Masterworks begins with your choice of our finest hand selected shell veneers and precision engineered premium hardware appointments. Choose your own combination or one of our Sonic-Select Shell recipes to customize a sound and look that is completely your own.

MASTERWORKS SONIC-SELECT URBAN RECIPE
NATURAL WALNUT BURST BUBINGA AND ROSETTE INLAY

DRUM SHELL TONE WOODS

Choose one or a combination of our premium shell materials to sculpt the sound of each drum.



MAPLE
Tonally equal in highs, mids, and lows for prime, full bodied attack and sustain.

BIRCH
Boosted attack with "Built-in EQ" for articulate and evenly reduced decay.

AFRICAN MAHOGANY
Dark, elegant tone with powerful bottom-end emphasis.

GUMWOOD
As a core or interior ply, Gum enhances tone in surrounding plies.

CUSTOM INTERIOR
Choose any of Pearl's Artisan Exotic veneers, carbon fiber, or hand applied fiberglass for boutique tones and visuals.

SHELL SIZE AND THICKNESS

For precise tonal character, sustain, and projection.



THIN (4-ply, 5mm w/ 4-ply Reinforcement Rings) Increased sustain and low-end.

MEDIUM (Even 6-Ply, 5.4mm) Expanded tonal purity and resonant punch.

STANDARD (6-ply, 7.5mm) Full-bodied tonal projection ideal for general purpose.

THICK (8-ply, 10mm and 10-ply, 12.5mm) Maximum projection and quick decay.

FINISHES

Craft an inspired visual statement with drums hand finished and configured to your specifications.

LUXURY
Includes a choice of High Gloss, Satin Stain, and Sparkle Lacquer.

CUSTOM
Includes Pinstriping, Banding, Artisan II Custom Graphics.

ARTISAN
Choose from a selection of Exotic veneers (below) or hand applied Carbonply.

CUSTOM INLAY
Accentuate the natural beauty of the outer shell finish with inlay bands inserted by hand.



CAMEROON BLACK LIMBA

FLAME MAPLE

AFRICAN ZEBRAWOOD

TAMO ASH

BUBINGA

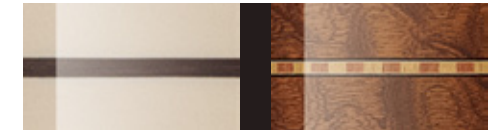

BARNWOOD

MOSAIC

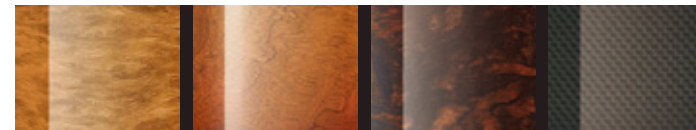

EUCALYPTUS

BURL MAHOGANY

IMBUIA

CARBONPLY

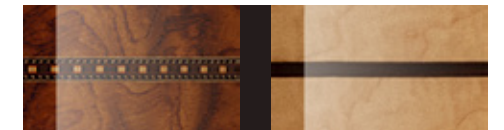

ROSETTE

EBONY

BEARING EDGE

Masterworks offers a choice of five sonically tested edges - configurable by drum, application, and shell side.



STANDARD 45°
Provides the perfect blend of attack and warmth.

OUTER 60°
Pulls brighter overtones and increases punch.

INNER 45°
Edge apex focused to inner shell plies for controlled sustain.

ROUNDED 45°
Increased head-to-shell contact boosts mids and highs.

FULLY ROUNDED
Boosts mid-to-low range response and reduces decay.

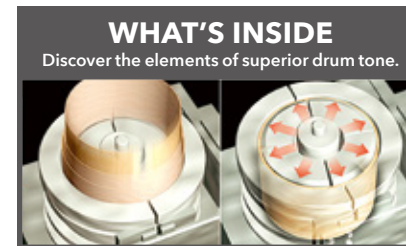

THE EST DIFFERENCE - The Ultimate in Strength, Resonance, and Tone.
Superior Shell Technology

To craft multi-ply, bonded drum shells with single-ply resonance and strength, Pearl pioneered the world's first high temperature hydraulic curing system. SST shells are formed in a bonded combination of cross-laminated

2-ply veneer panels then precision milled with overlapping scarf joint seams and cured with our exclusive AcoustiGlue at 1000 PSI of hydraulic pressure.

HARDWARE FINISH, LUG, AND HOOP OPTIONS

A choice of five plating options comes standard on your selection of our precision tuning lugs, hoops, and drum hardware.



CHROME
(Shown w/ CL-100 Lug)

NICKEL
(Shown w/ STL-100 Lug)

BLACK NICKEL
(Shown w/ STL-150 Lug)

GOLD
(Shown w/ STL-150 Lug)

BLACK CHROME
(Shown w/ STL-100 Lug)

LUGS

- Bridge (CL-100)
- Single Swivel (STL-100)
- Swivel Tube (STL-150)

HOOPS



MASTERCAST



2.3mm SUPERHOOP II

TOM MOUNT (U.S. Patent #11640814)



FOR 12.7mm VERTICAL ROD



FOR 7/8" HORIZONTAL PIPE



STUDIO

MASTERWORKS SONIC-SELECT STUDIO RECIPE SHELLS
IN GREY METALLIC WITH BLACK NICKEL HARDWARE



SONIC-SELECT SHELL RECIPES

CHOOSE YOUR ARENA. CREATE YOUR DREAM. DEFINE YOUR SOUND.

Our Sonic Select Shell Recipes narrow the nearly endless scope of Masterworks choice down to five sonically proven shell and hardware combinations. Each recipe is individually primed for its distinct performance environment.

STUDIO

Explosive tonal clarity and articulation for recording.
SHELL: EvenPly-Six (5.4mm) Maple/Gumwood w/ Outer 60° Bearing Edge

STADIUM

Pearl's thick CZX Maple shell for high-volume power.
SHELL: Fl.Toms/Bass: 10-ply Maple w/ Outer 60° Bearing Edges. Toms/Snares: 8-ply Maple w/ Outer 60° Bearing Edges

URBAN

A thin, powerful blend for the precise metropolitan drummer.
SHELL: Toms/Bass: EvenPly-Six Birch/Gumwood/Birch (5.4mm) with 4-ply Maple Re-Rings and mixed Bearing Edges

HERITAGE

Classic drum feel with enhanced lows and fat top-end slap.
SHELL: 4-ply Maple/Mahogany w/ 4-ply Maple Re-Rings w/ Standard 45° Bearing Edge

MODERN DRY

Quick, top-heavy articulation with controlled low-end.
SHELL: 4-ply Maple/Gumwood w/ 4-ply Mahogany Re-Rings w/ Inner 45° Bearing Edges

CUSTOMIZED TO FIT YOUR CREATIVE VISION.

Like a blank canvas for your drumming ideal, modify any Sonic-Select Shell Recipe shell or hardware option to give it your own spin or use our exclusive Artisan II process to embed your choice of high definition graphics directly onto the outer shell.

SEE www.pearldrums.com/masterworks FOR FULL DETAILS

STUDIO

SHELL	EvenPly-Six (5.4mm), 4-ply Maple Outer with 2-ply Gumwood Inner
BEARING EDGE	Outer 60°
HOOPS	MasterCast Hoops
LUGS	CL Bridge Lug CL-100 (Toms) CL-250 (Bass Drum)
SPURS	SP-330
FT BRACKETS	LB-75

A POWERFUL SONIC FOUNDATION TUNED FOR THE RECORDING ENVIRONMENT.

This commanding shell/edge combination of hard exterior and milder tone woods yields explosive midrange projection and extended low end punch.



SHELL
Thin, resonant combination of a hard exterior with milder tonewood for explosive low-range warmth.



BEARING EDGE
Outer 60° Gives increased power and bite to a thinner hybrid shell.



HOOPS
MasterCast Hoops. Escalates weight for tonal body. Increases volume in high velocity play.



LUGS
CL Bridge Lug A classic look with minimal shell contact for precise vibration control.



Sonic-Select Shell Recipes

STADIUM

URBAN

A FRESH SONIC DRUM BLEND FOR THE METROPOLITAN PLAYER.

From sold out tours to sanctuary halls, the tonal dichotomy of three proven hardwoods projects with a defiant top end and fills the bass frequencies with thunderous, shaking lows.

URBAN			
SHELL	EvenPly-Six (5.4mm Toms/Bass)	HOOPS	2.3mm SuperHoop II*
	2-Birch/2-Gumwood/2-Birch with	LUGS	STL Swivel Tube Lugs*
	4-ply Maple Re-Rings		STL150* (Toms)
	8-ply Snare Drums		STL300* (Bass Drum)
	2 Birch/4 Gumwood/2 Birch	SPURS	SP330
BEARING EDGE	Rounded 45° on Toms	FT BRACKETS	LB75
	Fully Rounded edge on Bass Drums Standard 45° on Snare Drums		

*Recommended



STADIUM	
SHELL	10-ply Maple Bass Drum & Floor Toms 8-ply Maple Toms and Snare
BEARING EDGE	Outer 60°
HOOPS	2.3mm SuperHoop II* CL Bridge Lug CL-100 (Toms) CL-250 (Bass Drum)
LUGS	CL-100 (Toms) CL-250 (Bass Drum)
SPURS	SP-330
FT BRACKETS	LB-75

*Recommended

THE CZX SOLUTION FOR HIGH VOLUME, RHYTHMIC COMMAND.

Pearl's legendary high density CZX Maple shell is reborn! Our classic 10-ply /8-ply shell combination delivers penetrating volume, articulate midrange attack, and focused low end.



MASTERWORKS SONIC-SELECT STADIUM RECIPE SHELLS IN SATIN NATURAL ARTISAN BURL MAHOGANY FINISH WITH MOSAIC INLAY AND GOLD HARDWARE

MASTERWORKS SONIC-SELECT URBAN RECIPE SHELLS IN ARTISAN EXOTIC - BLACK BURST TO BLUE OVER BLACK LIMBA



SHELL
A thick shell for dominating volume and articulate attack.



BEARING EDGE
Outer 60°
Increases brightness and power with controlled overtone.



HOOPS
2.3mm SuperHoop II Hoops - Made to withstand heavy play while allowing the shell to breathe.



LUG
CL Bridge Lugs
Heavier weight increases attack and assures the ultimate in tuning integrity.

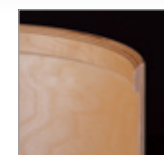

SHELL
Dense, thin shell hybrid for precise punch and quick, even decay.



BEARING EDGE
Rounded 45° on Toms (Fully Rounded edge on Bass Drums, Standard 45° on Snare Drums).



HOOPS
2.3mm SuperHoop II Hoops - Made for heavy play without limiting tuning range performance.



LUG
STL Swivel Tube Lug
A medium-weight lug with pivoting tension casing for increased projection and reduced overtone.

HERITAGE

MODERN DRY



(Masterworks Heritage Kit not shown)

HERITAGE	
SHELL	Maple 2-ply outer Mahogany 2-ply inner w/ 4-ply Maple Re-Rings
BEARING EDGE	Standard 45°
HOOPS	2.3mm SuperHoop II Hoops*
LUGS	STL-100* (Toms) STL-200* (Bass Drum)
SPURS	SP-330
FT BRACKETS	LB-75

*Recommended

TIMELESS, ORGANIC TONE WITH SMOOTH LOW-END GROWL

The Heritage Recipe's robust blend of reinforced Maple/ Mahogany delivers solid midrange punch with exceptional sustain and thunderous sub bass frequencies.

MODERN DRY	
SHELL	2-ply Maple outer/2-ply Gumwood inner with 4 ply Mahogany Re-Rings
BEARING EDGE	Inner 45°
HOOPS	MasterCast Hoops*
LUGS	STL-100 (Toms) STL-200 (BD)
SPURS	SP-330
FT BRACKETS	LB-75

*Recommended

DARK NATURAL PUNCH FOR DRIVING, ORGANIC BEAT MAKING.

The Modern Dry Recipe blends three sonically unique tone woods for dark, controlled tone, and pillowy response. Its unique blend of shell and hardware elements adds bottom end focus and throaty punch.

MASTERWORKS SONIC-SELECT MODERN DRY RECIPE SHELLS WITH ADDED ROCKET TOMS IN #109 ARCTIC WHITE LACQUER FINISH

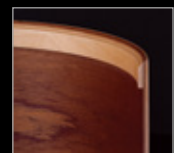

SHELL
A traditional blend of midrange punch and boosted low-end.

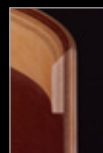

BEARING EDGE
Standard 45° - Precise, low-contact edge for added projection and resonance.



HOOPS
2.3mm SuperHoop II Hoops - Made to withstand heavy play while allowing the shell to breathe.



LUG
Single Swivel Lug
A classic look with minimal shell contact for precise vibration control.



SHELL
A unique blend of yielding tone woods and rigid exterior for added bottom-end focus.



BEARING EDGE
Inner 45°
Its inner shell apex contacts the head inside the shoulder for focused control in low tunings.



HOOPS
MasterCast Hoops - Gives each drum added weight for increased volume and controlled sustain.



LUG
Single Swivel Lugs
Our lightest and most efficient tuning lug for reduced shell contact.

Reference ONE

The Reference Legacy...
Unleashed.



A TRUE PEARL ORIGINAL, WITH A FRESH, GROOVE INSPIRING VIBE.

Where the Many Combine to Create a Singular Instrument. Building on the modern hybrid drum concept Pearl originated with Reference Series, every element in the Reference One drum set's construction is fine-tuned to deliver optimal performance. By leveraging specific woods, shell thicknesses, and bearing edges exactly where they are most sonically beneficial within a drum set, Reference One's reduced-thickness EvenPly shells are fitted with MasterCast Die-Cast hoops, for a radical combination sustain and attack. Combined with Pearl's revolutionary R2 Air Tom Suspension System, Reference One takes the hybrid drum concept to new, unprecedented heights.



R2 AIR TOM SUSPENSION SYSTEM

Suspends each drum by four unique points for optimum tone and resonance at any angle. (U.S. Patent #11640814)



MASTERCAST HOOP

Escalates weight for tonal body and increases volume in high velocity play.



SINGLE SWIVEL LUGS

Single Swivel Lugs are self-aligning for better tuning integrity and reduced shell stress. Their reduced profile takes up less room on the shell face, delivering better tone from each drum.



GOLDEN RATIO AIR VENT

The Golden Ratio air vent location is unique for each component size to provide enhanced tonal character and frequency response. (U.S. Patent # 7485791)



RF1P983XP/L
#124 Matte Black Mist









RF1P924XSPS/C
#859 Putty Grey

SHELL	Refer to Size / Shell Chart
SNARE	Matching 13"x6.5", 14"x5", 14"x6.5", 14"x8"
FINISH	CHOICE of 28 Hand-Applied Premium or Custom Lacquer Finishes
HEADS	Remo Coated Ambassador, Powerstroke3 Bass
TOM MOUNTS	R2 Air Tom Suspension system (U.S. Patent #11640814)
TOM ARMS	CHOICE of Pearl's Traditional 7/8" Pipe Holder or 12.7mm Solid L-Arm (Sold Separately)
DRUM HARDWARE	Chrome (Standard) Black nickel, Nickel and Black Chrome (Premium Charge)
HOOPS	MasterCast Hoops
LUGS	STL Single Swivel Lugs
BD MUFFLER	BDM-F

SHELLS

Each drum has its own custom shell, edge, and thickness profile to best suit its place in the drum set.



REFERENCE RECIPE	SHELL TYPE	BEARING EDGE	SONIC OUTPUT
8" and 10" Toms	 Maple(4)/Birch(2) 6-ply (5.4mm)	Rounded 45°	Cutting projection for high-note pitch
12" Toms	 Maple(6) 6-ply (5.4mm)	Rounded 45°	Transitional mid-note; blend of warmth and cut
13" Toms	 Maple(4)/Mahogany(2) 6-ply (5.4 mm)	Rounded 45°	Top-end slap with added low/bottom end
14" and 15" Toms	 Maple(4)/Mahogany(2) 6-ply (5.4 mm)	Fully Rounded	Bracing low-end with controlled punch
16" Toms	 Maple(2)/Mahogany(4) 6-ply (5.4mm)	Fully Rounded	Full, rounded sustain and gated attack
14" Floor Toms	 Maple(4)/Mahogany(4) 8-ply (7.2mm)	Fully Rounded	Fat, controlled low-end with smooth roll-off
16" and 18" Floor Toms	 Maple(2)/Mahogany(6) 8-ply (7.2mm)	Fully Rounded	Fat, controlled low-end with resonant warmth
18" and 20" Bass Drums	 Maple(2)/Mahogany(4) 6-ply (5.4mm)	Fully Rounded	Quick and Punchy with Powerful low-end
22" and 24" Bass Drums	 Maple(2)/Mahogany(6) 8-ply (7.2mm)	Fully Rounded	Booming bass tone with articulate punch

Masters

The Masters You Remember,
A Sound You'll Never Forget

ELEVATING THE PLAYING EXPERIENCE FOR THE TRUE PROFESSIONAL.

Pearl's Masters Series has set a standard for the very best in performance centered instruments for the pro drummer. In celebration of three decades of Masters quality and excellence, Pearl reimagines three original shell recipes with a freshly unified hardware mix to reach new levels of sonic purity the most discerning environments and players.

MASTERS SHELL CHOICES



MASTERS MAPLE/GUM (MMG)

Masters Maple/Gum (MMG) Primed for the Recording Studio, this legendary shell blend enhances the naturally vibrant sonic nature of Maple with explosive highs and lows.



MASTERS MAPLE PURE (MP4)

The Original Masters Sound delivers full bodied resonant tone with increased lows and a more focused attack.

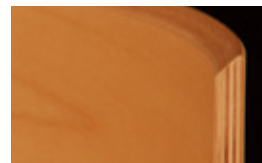

MASTERS MAPLE (MM6)

Originally offered as Masters MRX, projects powerfully expressive tone fit for evolving live music environments. Sonically centered with equal Highs/Mids/Lows.

MASTERS HARDWARE SELECTION

Adding the groundbreaking R2 Air Tom Suspension system's four point mounting platform to Pearl standards like premium North American shell veneers and MasterCast Die-Cast Hoops, Masters Series is the defining essence of the Pearl Sound and tailored to fit your sonic vision.



MASTERS MAPLE GUM KIT (MMGP924XSPL/C)
IN #844 SATIN ROSE GOLD LACQUER FINISH
ON CONFIGURED ICON RACK SYSTEM WITH ADDED 8"x7"
AND 13"x9" TOMS AND 14"x14" FLOOR TOM



R2 AIR TOM MOUNTS
Suspends each drum by four unique points for optimum tone and resonance at any angle. (L-Arm bracket shown)
U.S. Patent #11640814



PEARL STANDARD 7/8" PIPE OR 12.7mm L-ARM BRACKETS
A choice of Vertical or Horizontal Mounting and flexibility. (Standard bracket shown)



MASTERCAST HOOPS
The ultimate choice for durability and tuning integrity, they increase overall shell weight for enhanced tonal body and volume.



CL BRIDGE LUGS
A classic look with minimal shell contact for precise vibration control.

Masters

MAPLE/GUM
HANDCRAFTED SHELL

The Evolution of
Premium Studio Tone



THE MASTERWORKS STUDIO RECIPE, SIMPLIFIED.

Delivering arguably the greatest drum tones ever recorded, Pearl's performance-centered take on the legendary Maple/Gum shell recipe is a sonic experience every drummer needs to witness. Reaching epic levels in sonic warmth and explosive low-end response, this dynamic shell/hardware combination first debuted as the Masterworks Sonic Select Studio Recipe. With the addition of the R2 Air Tom Suspension System, this is an instrument that is perfectly at home in the Recording environment, and a true prize for each drummer that owns one.



OUTER 60° BEARING EDGE
Gives increased power and bite to a thinner hybrid shell.



R2 AIR TOM SUSPENSION SYSTEM
Suspends each drum by four unique points for optimum tone and resonance at any angle. (U.S. Patent #11640814)



MASTERCAST HOOPS
The ultimate choice for durability and tuning integrity, they increase overall shell weight for enhanced tonal body and volume.



CL BRIDGE LUGS
A classic look with minimal shell contact for precise vibration control.



MMGC923XDP/L
#855 Black Oyster Swirl

MMGC923XDPL/C
#453 Platinum Gold Oyster

MASTERS SHELLS

Only the finest cuts of North American hardwood are harvested for Pearl's Masterworks Shell Vault. Cross laminated into dual-layered panels, each veneer in the Masters shell has been hand selected from this exclusive cache to produce drums worthy of Pearl's commitment to quality and performance.

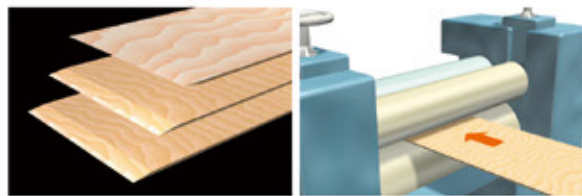

SUPERIOR SHELL TECHNOLOGY

The SST method was developed to craft a multi-ply, bonded drumshell with single-ply resonance and strength. All shells are precision milled with overlapping scarf joint seams and cured with our exclusive AcoustiGlue at 1000 PSI of hydraulic pressure.

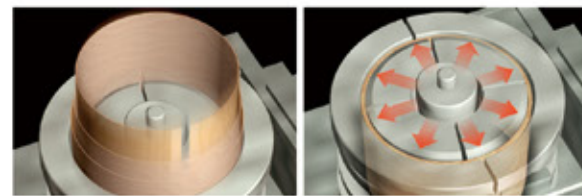

SHELLS

EvenPly-Six, 4-ply Maple outer with 2-ply Gumwood inside – The natural warmth of Maple is enhanced by Gumwood's dense, controlling character.



SHELL	EvenPly-Six (6-ply, 5.4mm) North American Maple / Gumwood
SNARE	Matching 13"x6.5", 14"x5", 14"x6.5", 14"x8"
FINISH	CHOICE of 28 Hand-Applied Premium or Custom Lacquer Finishes
HEADS	Remo USA Coated Ambassador, Powerstroke3 Bass
TOM MOUNTS	R2 Air Tom Suspension System (U.S. Patent #11640814)
TOM ARMS	CHOICE of Pearl's Traditional 7/8" Pipe Holder or 12.7mm Solid L-Arm (Sold Separately)
DRUM HARDWARE	Chrome (Standard) Black Nickel, Nickel and Black Chrome (Premium Charge)
HOOPS	MasterCast Hoops
LUGS	CL Bridge Lugs
BD MUFFLER	BDM-F

Masters

MAPLE
ALL MAPLE SHELL

Sonically Centered,
Articulate, and Powerful.



A BOLD VOICE FOR HIGH VOLUME STAGE PROJECTION.

With a sound that sits in the tonal center of the mix, Masters Maple is Pearl's original 6-ply shell recipe. This timeless combination of a slightly thicker 6-ply North American Maple shell and a sharper 45-degree bearing edge produces enough precise projection to shake the rafters, yet is responsive to even the slightest stroke. With an equalized high/mid/low tonality, Masters Maple is primed for cutting, vibrant live performance.



STANDARD 45° BEARING EDGE

Pearl's original precision edge adds sustain through reduced shell-to-head contact.



R2 AIR TOM SUSPENSION SYSTEM

Suspends each drum by four unique points for optimum tone and resonance at any angle. (U.S. Patent #11640814)



MASTERCAST HOOPS

The ultimate choice for durability and tuning integrity, they increase overall shell weight for enhanced tonal body and volume.



CL BRIDGE LUGS

A classic look with minimal shell contact for precise vibration control.



MM6C923XDPS/C
#824 Satin Charred Oak

MM6P923XDPS/C
#858 Kobalt Blue Fade

MASTERS SHELL HARDWARE

Die-Cast for solid stability in the most demanding conditions, the appointments on each Masters shell were designed to draw the best tone from the shell they support. Mastercast Hoops, low mass CL Bridge Lugs, a choice of mounting options with the R2 Air Tom Suspension System, and refreshed adjustable Bass Drum Spurs and Floor Tom Brackets are standard.



USA REMO DRUM HEADS

All Pearl Masters come with REMO USA Drum Heads. Toms feature Coated Ambassador Batters with Clear Ambassador Resonant heads. Bass Drums are furnished with Powerstroke 3 Batter and Resonant heads, and come with our exclusive adjustable Dampening Pillow (BDM-F).



SHELLS

6-ply, 7.5mm hand-selected North American Maple with Veneers from Pearl's Masterworks Vault.



SHELL	6-Ply, 7.5mm North American Maple
SNARE	Matching 13"x6.5", 14"x5", 14"x6.5", 14"x8"
FINISH	Choice of 28 Hand-Applied Premium or Custom Lacquer Finishes.
HEADS	Remo USA Coated Ambassador, Powerstroke3 Bass
TOM MOUNTS	R2 Air Tom Suspension System (U.S. Patent #11640814)
TOM ARMS	CHOICE of Pearl's Traditional 7/8" Pipe Holder or 12.7mm Solid L-Arm (Sold Separately)
DRUM HARDWARE	Chrome (Standard) Black Nickel, Nickel and Black Chrome (Premium Charge)
HOOPS	MasterCast Hoops
LUGS	CL Bridge Lugs
BD MUFFLER	BDM-F

Masters

MAPLE PURE
ALL MAPLE SHELL

Bridging the Gap Between
Studio and Stage.



A POWERFUL TONAL BLEND OF RESONANCE AND ATTACK.

Pearl reimagines the original Masters shell recipe with Masters Maple Pure. Blending four layers of hand-curved North American Maple with 4-ply Re-Rings from our Masterworks Veneer Vault, its premium shell formula delivers a sonic fusion of near-field resonance and sharp top-end attack for varied pro environments. These hand-curved Maple plies increase the overall Janka hardness of the shell for increased projection, improved sustain, and better sonic output than ever before.



STANDARD 45° BEARING EDGE

Standard 45° – Pearl's original precision edge adds sustain through reduced shell-to-head contact.



R2 AIR TOM SUSPENSION SYSTEM

Suspends each drum by four unique points for optimum tone and resonance at any angle. (U.S. Patent #11640814)



MASTERCAST HOOPS

The ultimate choice for durability and tuning integrity, they increase overall shell weight for enhanced tonal body and volume.



CL BRIDGE LUGS

A classic look with minimal shell contact for precise vibration control.



MP4C923XDPS/C
#415 Bronze Oyster

MP4924XSPS/C
#831 Matte Olive Burst

MASTERS SELECTION

Pearl is committed to offering each drummer a top-tier experience in selecting and purchasing their Masters Series kit. Available for immediate delivery in a curated variety of in-stock components, Masters gives you the freedom of configuring your ideal set-up without the restriction of pre-formatted shell packs.



MASTERS FINISHES

Available in a wide range of Premium and Custom exterior lacquers, Masters drum finishes are hand-applied through Pearl's painstaking thirty-one step process. Choose from over 20 different Transparent, Metallic, Fade, Burst, Sparkle, Swirl, or Stripe Lacquers for your own unique statement.



SHELLS

5mm 4-ply shell w/4-ply Re-Rings blends hand-selected North American Maple Veneers from Pearl's Masterworks Vault.



SHELL	4-Ply, 5mm Maple w/4-ply Reinforcement Rings
SNARE	Matching 13"x6.5", 14"x5", 14"x6.5", 14"x8"
FINISH	CHOICE of 28 Hand-Applied Premium or Custom Lacquer Finishes.
HEADS	Remo Coated Ambassador, Powerstroke3 Bass
TOM MOUNTS	R2 Air Tom Suspension System (U.S. Patent #11640814)
TOM ARMS	CHOICE of Pearl's Traditional 7/8" Pipe Holder or 12.7mm Solid L-Arm (Sold Separately)
DRUM HARDWARE	Chrome (Standard) Black Nickel, Nickel and Black Chrome (Premium Charge)
HOOPS	MasterCast Hoops
LUGS	CL Bridge Lugs
BD MUFFLER	BDM-F

PROFESSIONAL SERIES

ALL MAPLE SHELL

Est. 1986. An Updated, Upgraded, Premium Gigging Powerhouse.



A PLAYER-READY DRUM SET PLATFORM FIT FOR ACTIVE GIGGING AND TOURING..

From local gigs to national tours, Pearl's updated Professional Series drums have a look and sound that fits in any live performance space. Beginning in 1985, Pearl introduced its legendary MLX drums under the Professional Series banner to bring the powerful Maple sound to the forefront. Today, Professional Series returns with the spirit of the original and a refreshed presence for the experienced drummer.



STANDARD 45° BEARING EDGE

Standard 45° - Pearl's original precision edge adds sustain through reduced shell-to-head contact.



OPTIMOUNT SUSPENSION SYSTEM

A solid, flexible four point suspension mount for prime shell resonance.



2.3mm SuperHoop II

Made to maintain tuning integrity in heavy play while delivering maximum shell resonance.



RL LUGS

A simple, sleek lug that adds weight to the shell for increased volume.



PMX904XSP/C
#414 Ice Blue Oyster

PMX924XSP/C
#883 Matte Mocha Swirl

PERFORMANCE PROVEN

Made for lively sonic warmth from the cockpit, Professional Series drums broadcast with a broad frequency spectrum on and off the gig. A host of transparent Gloss Lacquer (and one Premium wrap) finishes assure a solid look and feel in varied venues and climates.



HARDWARE

Our classic RL Lug, OptiMount Tom Suspension System, 2.3mm SuperHoop II, and Remo UT Pinstripe heads are added for strength and stability. Finally, to save your stand footprint and cartage load, Pearl's original Uni-Lock independent bass drum mounted tom holders deliver maximum adjustability and positioning without robbing the shells of tone or sustain.



SHELLS

EvenPly-Six (5.4mm) North American Maple - Fuses reduced thickness, cross laminated ply panels for expanded tonal purity and increased resonance.



SHELL	EvenPly-Six (5.4mm) North American Maple
SNARE	Matching 14"x 5", 14"x 6.5", 14"x 8"
FINISH	Premium Transparent Lacquer and USA Covered Finishes
HEADS	Remo UT Pinstripe Batter Heads
TOM MOUNTS	OptiMount Suspension System
TOM ARMS	TH-1030I x2 (with BB only)
DRUM HARDWARE	Chrome
HOOPS	2.3mm SuperHoop II
LUGS	RL Lugs
BD MUFFLER	BDM-M

SESSION STUDIO SELECT

A Completely New Take
on the Full Spectrum Sound



A TRUE PEARL ORIGINAL, WITH A FRESH, GROOVE INSPIRING VIBE.

Taking a tip from the Masterworks spectrum, Session Studio Select's unparalleled combination of Masters-grade Birch and African Mahogany deliver a refined standout for recording and gigging.

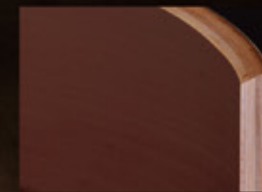

OUTER 60° BEARING EDGE
Increases volume and punch without harsh overtones.



OPTIMOUNT SUSPENSION SYSTEM
A solid, flexible four point suspension mount for prime shell resonance.



2.3mm SuperHoop II
Made to maintain tuning integrity in heavy play while delivering maximum shell resonance.



RL LUGS
A simple, sleek lug that adds weight to the shell for increased volume.



STS904XP/C
#314 Gloss Barnwood Brown

HARDWARE PARTS

Our classic RL Lug, OptiMount Tom Suspension System, 2.3mm Superhoop II hoops, and Remo UT Pinstripe heads are added for strength and stability.



STS924XSP/C
#851 Emerald Ash

SHELL	EvenPly-Six (6-ply, 5.4mm) Birch/African Mahogany
SNARE	14"x 5.5", 14"x 6.5", or 14"x 8" Matching Wood
FINISH	Premium Wrapped or Lacquer
HEADS	Remo UT Pinstripe Batter Heads
TOM MOUNTS	OptiMount Suspension System
TOM ARMS	Sold Separately
DRUM HARDWARE	Chrome
HOOPS	2.3mm SuperHoop II Hoops
LUGS	RL Lugs
BD MUFFLER	BDM-M

SHELLS

EvenPly-Six Birch/African Mahogany. An unique sonic dichotomy of piercing projection, smooth low-end and pre-EQ'd punch.



PRESIDENT

A Modern Revival of The Darkly Unique Luan Sound



DELIVERING A DISTINCTLY CLASSIC PLAYER'S GROOVE.

Drawing from the very origins of Pearl's manufacturing legacy, President Deluxe Series showcase the warm subtlety of our original tone wood for a traditionally full, controlled playing experience. Featuring our original 6-ply Luan shell, this darker toned medium/hardwood was the basis of thousands of shells made by Mitsuo Yanagisawa in Pearl's Chiba, Japan-based drum factory starting in 1961.



ROUNDED 45° BEARING EDGE

Increased head-to-shell contact boosts mids and highs and helps control overtone spread.



2.3mm SuperHoop II

Made to maintain tuning integrity in heavy play while delivering maximum shell resonance.



BSL LUGS

"The Battleship Lug", BSL100 features the same striking design of the original "C043" lug in a more robust casting for better tuning integrity.



SHELLS

6-ply 7.5mm Luan. Loud yet subdued with deep, punchy wallop and plenty of top-end attack.



PSD943XP/C
#767 Ocean Ripple

PSD903XP/C
#768 Desert Ripple

A MODERN TAKE ON A FAMILIAR FAVORITE

President Series Deluxe drums feature prime vintage style without the shortcomings of yesterday's fittings. Available in three shell packs with a host of component add-ons, each President Series Deluxe drum kit comes standard with Remo CS "Black Dot" UT heads, classic felt bass drum muffling strip, shell-mounted cymbal holder, and adjustable "Gullwing" style bass drum spurs.



SINGLE-HEADED CONCERT TOM SET

A period-correct companion to President Series Deluxe shell packs. Includes 8"x6" and 10"x7" single headed toms with Traditional Slide/Clip mounts.



SHELL	6-ply 7.5mm Luan
SNARE	14" x 5.5" * Sold Separately
FINISH	Premium USA Wraps
HEADS	Remo UT CS Black Dot Batters Smooth White Coated Ambassador w/ Classic Pearl Logo
SPURS	BSP-835 "Gullwing" Style
BD CYMBAL MOUNT	CHB-75LB
HOOPS	2.3mm SuperHoop II
LUGS	Battleship Lugs (BSL-100 (Toms), BSL-200 (Bass Drum))
BD MUFFLER	BDM-F and Resonant Felt Strip

CRYSTAL BEAT

50 Years of the Original
Seamless Acrylic Drum Shell



THE ORIGINAL SEAMLESS ACRYLIC DRUM SET

Beginning in 1973, Pearl established a revolutionary alternative to conventional drum making with Crystal Beat's 6mm/7mm molded/seamless Acrylic shell. Its vivid combination of cutting tonal power and stunning visual appeal found an immediate audience with the high-volume power player. In celebration of this 50 year milestone, Pearl introduces three never before released acrylic finishes in a Limited Edition selection of Crystal Beat shell packs. Released quarterly throughout the year in Small Batch production runs, each shell pack is built to stand up to the rigors of touring with an undeniably unique look and straight-tone power.



STANDARD 45° BEARING EDGE

Pearl's original precision edge adds sustain through reduced shell-to-head contact.



OPTIMOUNT TOM SUSPENSION SYSTEM

A solid, flexible four point suspension mount for prime shell resonance.



1.6mm STEEL HOOPS

Solid tuning performance with reduced weight.



CRBL LUGS

Each sleek and efficient lug is individually isolated from shell contact with nylon gaskets to prevent hardware rattle in play.



CRB503PC
#730 Ultra Clear

Crystal Beat Series
#730 Ultra Clear
ICON Rack System + Eliminator Demon XR Pedals

SHELL	6mm (7mm on Bass Drums) Seamless Molded Acrylic
SNARE	Matching Free Floater (Sold Separately)
FINISH	Transparent
HEADS	Transparent 2-Ply on Tom Batters Single-Ply Resonant
TOM MOUNTS	OptiMount Suspension System
TOM ARMS	Sold Separately
DRUM HARDWARE	Chrome
HOOPS	1.6mm Steel
LUGS	CRBL Lugs

SHELLS

Loud and immediate, delivers pummeling straight tone and yielding feel. Dual 45° bearing edge with a rounded apex, adding control and increased articulation to acrylic's sonic signature.

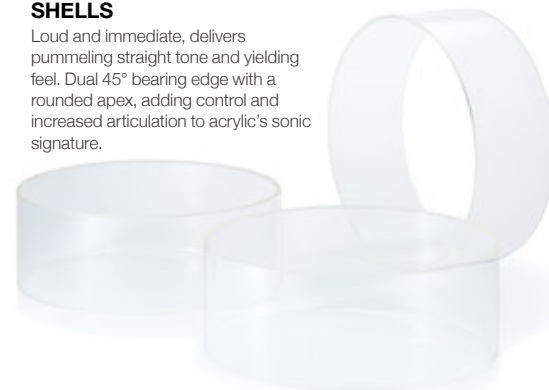

DECADE MAPLE

A Drum Kit
10 Years in the Making



BUILT TO PUSH THE BOUNDARIES OF PERFORMANCE AND PRICE

Decade Maple Series drums elevate the playing field for the advancing drummer with pro features and unbeatable value. Over seven decades of Pearl drum craftsmanship and ten full years of research and development culminate in the ideal step up drum kit: Decade Maple Series. Escalating the playing field for the advancing drummer, Decade Maple's featured shell packs are perfect as a primary kit for evolving players or a secondary "gigging" kit for the seasoned pro.



STANDARD 45° BEARING EDGE

Pearl's original precision edge adds sustain through reduced shell-to-head contact.



OPTI-LOC MOUNTING SYSTEM

This three-point isolation mount suspends the drum at two tuning points and one of the drum's air vents for solid, stable play.



1.6mm STEEL HOOPS

Solid tuning performance with reduced weight.



NDL LUGS

Small, efficient, and strong, the NDL lug is designed to hold tuning across all points without taking up too much room on the shell.



DMP925SP/C+18x16 Floor Tom
#884 Ice Mint

DMP925SP/C
#899 Matte Racing Red

BDMM BASS DRUM MUFFLER

Brings out the PUNCH in your kick.



HARDWARE

- Uni-Lock gearless Tom Arms.
- R-40 Air Suspension Floor Tom feet.
- ND Lugs: For reliable, rock solid durability and sound.



SHELLS

EvenPly-Six / 5.4mm Maple - Thin (but powerfully strong) Pearl's SST shell reacts quickly to the stroke with beautifully resonant highs and thundering lows.



SHELL	EvenPly-Six (5.4mm) 100% Maple
SNARE	Matching 14"x 5.5"
FINISH	High-Gloss / Matte Lacquer
HEADS	Remo UT Clear Ambassador Tom, Ported UT Powerstroke3 Bass
TOM MOUNTS	Opti-Loc Mounting System
DRUM HARDWARE	Chrome
HOOPS	1.6mm Steel Hoops
LUGS	NDL Lugs



The Legends of Tomorrow,
Play Export Today



THE BEST SELLING DRUM SET OF ALL TIME.

THE BEST SELLING DRUM SET OF ALL TIME
The Export Series 30 year pedigree of unbeatable quality and value shines on with Reference-inspired shell woods and high impact hardware, giving the rising player a truly high end playing platform. Export Series drums are available in three preconfigured packages with our robust 830 Series hardware; and feature a choice of durable wrapped (EXX) finishes. Pearl carries this tradition forward with our best Export ever - fully loaded with all the features to advance your playing voice to new heights. Never settle. Play Export.



STANDARD 45° BEARING EDGE

Pearl's original precision edge adds sustain through reduced shell-to-head contact.



OPTI-LOC MOUNTING SYSTEM

This three-point isolation mount suspends the drum at two tuning points and one of the drum's air vents for solid, stable play.



1.6mm STEEL HOOPS

Solid tuning performance with reduced weight.



NEL LUGS

Small and elegant for reduced real estate on the shell, but efficient enough for tuning integrity in play.



EXX725S/C + 14"x14" Floor Tom
#777 Slipstream White



EXX725S/C
#778 Graphite Silver Twist

SHELL	6-Ply 7.5mm Poplar & Asian Mahogany Blend
SNARE	Matching 14"x5.5"
FINISH	Choice of 5 Covered Finishes
HEADS	Remo Clear Tom Head, Powerstroke Bass Head
TOM MOUNTS	Opti-Loc Mounting System
TOM ARMS	TH-70I
DRUM HARDWARE	Chrome
HARDWARE	P-930, BC-830, C-830, H-830, S-830



830 SERIES HARDWARE

Sophisticated, sturdy, and efficient, Export's 830 Series Boom (BC-830), Cymbal (C-830), and Snare (S-830) stands all feature gearless Uni-Lock Tilters for pinpoint positioning, and robust double-braced tripods for stability and security.



P930 PEDAL

Featuring the longboard styling and feel of Pearl's Demon Drive pedal, the P-930 offers two chain drive cam options for power, speed, and control. The matching H-830 Hi-Hat stand also features swivel legs that accommodate double pedals.



SHELLS

6-Ply 7.5mm Poplar & Asian Mahogany Blend (but powerfully strong) Pearl's SST shell reacts quickly to the stroke with beautifully resonant highs and thundering lows.

MIDTOWN

BIG GIG, SMALL RIG, HUGE SOUND



MT546/C
#747 Matte Red

SHELLS

6-Ply (7.5 mm) Poplar.
Quick and biting attack
with lively overtones.



FINISHES

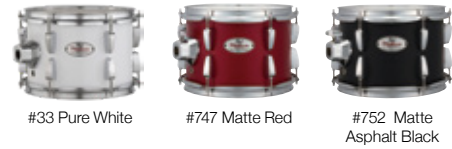

#33 Pure White

#747 Matte Red

#752 Matte Asphalt Black

HARDWARE

Lift used on Midtown raises the drum to the optimal position for your pedal.



CONFIGURATIONS

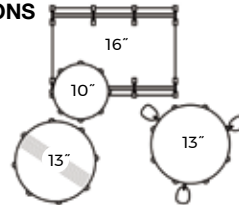

SETTING THE PULSE FOR THE METROPOLITAN GROOVE

The Midtown Series complete drum set is an ideal platform for on-the-go beatmaking in tight spaces. Its ultra-portable, compact 4-pc. shell pack and included lightweight stands are built for big grooves, from street to stage.

SHELL	6-Ply (7.5 mm) Poplar
SNARE	Matching 13"x5.5" Wood Snare Drum
FINISH	Choice of 3 Covered Finishes
HEADS	Coated Tom Self-Muffled Bass Coated Snare
TOM ARMS	THNRS
HARDWARE	Included single-braced Cymbal Boom, Hi-Hat, and Snare stands are light weight and rugged enough for easy transport and rapid set-up.

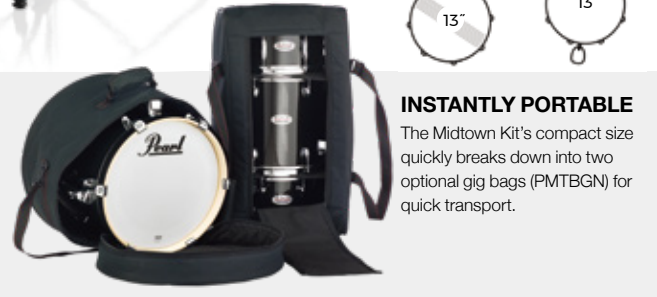

INSTANTLY PORTABLE

The Midtown Kit's compact size quickly breaks down into two optional gig bags (PMTBGN) for quick transport.

ROCKET TOMS

For striking staccato tone that's both melodic and piercing, Pearl's Rocket Toms are 6" pitched toms in varying lengths made to expand the sonic palette of any drum kit.

Available in sets or as individual components in Aluminum. Finishes: #103 Piano Black, #109 Arctic White, or #730 Ultra Clear Acrylic.



AL-0612/C	6" x 12"
AL-0615/C	6" x 15"
AL-0618/C	6" x 18"
AL-0621/C	6" x 21"
ALX-1215/C	6" x 12", 6" x 15" (w/ T890)
ALX-1821/C	6" x 18", 6" x 21" (w/ T890)
CRB-612/C	6" x 12" (Acrylic #730 Ultra Clear)
CRB-615/C	6" x 15" (Acrylic #730 Ultra Clear)
CRB-618/C	6" x 18" (Acrylic #730 Ultra Clear)
CRB-621/C	6" x 21" (Acrylic #730 Ultra Clear)

COMPACT TRAVELER

BASS DRUM	18" w/ Base Frame & L-Arm Handle
SNARE	10" w/ Adjustable Snare Rake
STANDS	Sold Separately
CARRYING CASE	PSC-PCTK (Sold Separately)
ADD ON PACK	PCTK-1014 Includes 10" & 14" Toms w/ Mounting Hardware

Take the rhythm on the road with Pearl's totally portable, super playable, ultra affordable beat maker. Perfect for School, Street, Practice, and Stage.



Shown with PCKT1014 add on pack* PCTK-1810



Pedal sold separately PCTK-1810

Add on pack (10" & 14" toms w/ mounting hardware) PCTK-1014

Optional Compact Traveler Bag PSC-PCTK
Optional Compact Traveler Add on Bag PSC-PCTKADD



RS525SBC
#747 Matte Red



ROADSHOW

IT'S YOUR TIME TO PLAY, START THE RIGHT WAY!

THE RHYTHM IS IN YOU

Drumming knows no age limit. Regardless of when your rhythmic journey starts, Pearl's Roadshow Series has a drum set package scaled for players of all ages that includes everything you need to get on the road to drumming greatness.

SHELL	6-Ply 7mm Asian White Poplar
SNARE	Matching Wood Snare
FINISH	Choice of 7 Covered Finishes
HEADS	Clear Tom Heads, Coated Snare Head, Self-Muffled Bass Head
TOM ARMS	Individually Locking 7/8" Tube Joint Holders
HARDWARE	Dual-Chain Drive Bass Drum Pedal Double-Braced Cymbal*, Snare and Hi-Hat Stands, Double-Braced Throne
CYMBALS	16" Brass Cymbal, 14" Brass/ Hybrid Hi-Hat Cymbals
ACCESSORIES	Pro Drum Stick Bag, Two pairs of Maple 5A Sticks

*Docking Cymbal Boom Arm Included with RS584C/C

CONFIGURATIONS

Complete Sets with Hardware, Cymbals, and Throne.
Includes CH50/H50/S50*/P50/D50/16" Crash/14" Hi-Hats, Stick Bag, Sticks

RS584C/C

RS505C/C

RS525SC/C

RS525WFC/C

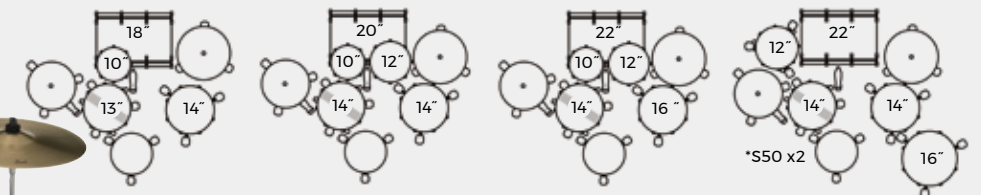

RS525SC/C
#91 Red Wine

THE HEART OF THE ROADSHOW SOUND.
Roadshow is crafted to be everything you'd expect from a Pearl Drum set, featuring a 9-ply Poplar shell for optimum tonal power.

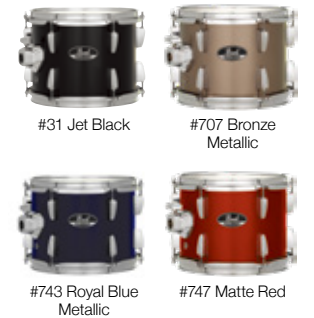

#31 Jet Black

#707 Bronze Metallic

#743 Royal Blue Metallic

#747 Matte Red

ROADSHOW JR.

Pearl's Roadshow Jr. is NOT a toy. It's a serious, all-in-one, five piece drum set sized for kids under 8-years-old featuring hardware, cymbals, and sturdy White Poplar shell construction for an exceptionally powerful drumming start.

Complete with Hardware, Cymbals, and Throne for Drummers under 8.

RSJ465/C

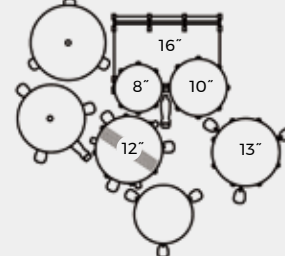

For additional info, testimonials, free assembly and instructional videos, and access to the largest drummer's community on the web, go to:



#31 Jet Black

#708 Grindstone Sparkle



M
Masterworks
PEARL DRUMS

M
Masterworks
PEARL DRUMS

Masterworks
M
PEARL DRUMS

SERIES COMPONENT

Reference One

Reference One

A nuanced, refined balance of sensitive response and sonic versatility, Reference One Series Snare Drums are an exceptional complement to the total sound of any drum set. Combining an EvenPly blend of hand-curved North American Maple and Birch, the 5.4mm Reference One shell delivers a smooth, resonant quality with heightened top-end pop at the hit. Each snare's hardware selection includes elements that balance overall weight from top to bottom, for supreme sensitivity and crisp projection.



Quick, yielding snap with heavy midrange tonality.
RF1P1450S/C



A sonic dichotomy of versatile crack and guttural punch.
RF1P1465S/C



Low, thunderous wallop with yielding power in play.
RF1P1480S/C

RF1P1450S/C	14" x 5"
SHELL	EvenPly-Six (5.4mm) Maple 4 + Birch 2
HOOPS	MasterCast (DC-1410 / DC-1410S)
LUGS	STL-100
RODS	SST-5047 (20)
STRAINER	SR-1000 (U.S. Patents #7220905 #7365256)
SNARES	SN-1420I (Using Cord)
HEADS	REMO Coated (A)

RF1P1465S/C	14" x 6.5"
SHELL	EvenPly-Six (5.4mm) Maple 4 + Birch 2
HOOPS	MasterCast (DC-1410 / DC-1410S)
LUGS	STL-100
RODS	SST-5047 (20)
STRAINER	SR-1000 (U.S. Patents #7220905 #7365256)
SNARES	SN-1420I (Using Cord)
HEADS	REMO Coated (A)

RF1P1480S/C	14" x 8"
SHELL	EvenPly-Six (5.4mm) Maple 4 + Birch 2
HOOPS	MasterCast (DC-1410 / DC-1410S)
LUGS	STL-100
RODS	SST-5047 (20)
STRAINER	SR-1000 (U.S. Patents #7220905 #7365256)
SNARES	SN-1420I (Using Cord)
HEADS	REMO Coated (A)

Reference One Brass

True to the Reference legacy of performance-proven instruments, Reference One Brass Snare Drums deliver unparalleled projection, power, and presence. Combining a formidable 3mm solid Brass shell with the reduced footprint of our STL Swivel Lugs lets each drum project with bell-like tonal clarity. The addition of MasterCast hoops, our slip free Glide-Lock strainer, and the sensitivity Ultra-Sound snare wires make each drum an absolutely vital instrument, from Studio to Stadium.



Crisp, High-End Pop with Fully-Centered Tonal Body.
RF1B1450



A Bold Combination of Bright Attack and Warm Power.
RF1B1465

RF1B1450	14" x 5"
SHELL	3mm Brass
HOOPS	MasterCast (DC-1410 / DC-1410S)
LUGS	STL-100
RODS	SST-5047 (20)
STRAINER	SR-1000 (U.S. Patents #7220905 #7365256)
SNARES	SN-1420D (U.S. Patent #7202405)
HEADS	REMO Coated (A)

RF1B1465	14" x 6.5"
SHELL	3mm Brass
HOOPS	MasterCast (DC-1410 / DC-1410S)
LUGS	STL-100
RODS	SST-5047 (20)
STRAINER	SR-1000 (U.S. Patents #7220905 #7365256)
SNARES	SN-1420D (U.S. Patent #7202405)
HEADS	REMO Coated (A)

Masters Maple Gum, Masters Maple, Masters Maple Pure Series

Masters Series

With shell recipes from each of the three branches of the Masters Series line-up, Masters Snare Drums' individually versatile nature is prime for the forward-focused drummer. Their collective rhythmic voice sings with the unity of a family of Maple instruments, but with enough tonal variety from model to model to make them totally unique. Available in four sizes and a kaliedescope of dazzling finishes, Masters Snares deliver the excellence you have come to expect from the world's leading drum maker.



MMG, MM6, & MP4 Snare Drums are Available in 13" x 6.5", 14" x 5", 14" x 6.5", and 14" x 8."



Exceptionally well-rounded sound for any groove.
MMGC1450S/C



Solid, high-centered tonal punch with full range body.
MMGC1465S/C



Full-Spectrum snare power with thick bottom-end focus.
MM6P1450S/C



Powerful attack with thick, mid-heavy overtone.
MM6C1465S/C



Top-end snap with crisp sensitivity and sustain.
MP4P1450S/C



Wide tuning range from thuddy to cracking volume.
MP4C1465S/C

MMGP1450S/C	14" x 5"
SHELL	EvenPly-Six (5.4mm) Maple 4 + Gumwood 2
HOOPS	MasterCast (DC-1410 / 1410S)
LUGS	CL-55
RODS	SST-5047 (20)
STRAINER	SR-17A / SR-150E
SNARES	SN-1420I (U.S. Patent #7202405)
HEADS	REMO Coated (A)

MMGC1465S/C	14" x 6.5"
SHELL	EvenPly-Six (5.4mm) Maple 4 + Gumwood 2
HOOPS	MasterCast (DC-1410 / 1410S)
LUGS	CL-65
RODS	SST-5047 (20)
STRAINER	SR-17A / SR-150E
SNARES	SN-1420I (U.S. Patent #7202405)
HEADS	REMO Coated (A)

MM6P1450S/C	14" x 5"
SHELL	6-ply (7.5mm) Maple
HOOPS	MasterCast (DC-1410 / 1410S)
LUGS	CL-55
RODS	SST-5047 (20)
STRAINER	SR-17A / SR-150E
SNARES	SN-1420I (U.S. Patent #7202405)
HEADS	REMO Coated (A)

MM6C1465S/C	14" x 6.5"
SHELL	6-ply (7.5mm) Maple
HOOPS	MasterCast (DC-1410 / 1410S)
LUGS	CL-65
RODS	SST-5047 (20)
STRAINER	SR-17A / SR-150E
SNARES	SN-1420I (U.S. Patent #7202405)
HEADS	REMO Coated (A)

MP4P1450S/C	14" x 5"
SHELL	4-ply Maple w/4 ply Maple Re-Rings
HOOPS	MasterCast (DC-1410 / 1410S)
LUGS	CL-55
RODS	SST-5047 (20)
STRAINER	SR-17A / SR-150E
SNARES	SN-1420I (U.S. Patent #7202405)
HEADS	REMO Coated (A)

MP4C1465S/C	14" x 6.5"
SHELL	4-ply Maple w/4 ply Maple Re-Rings
HOOPS	MasterCast (DC-1410 / 1410S)
LUGS	CL-65
RODS	SST-5047 (20)
STRAINER	SR-17A / SR-150E
SNARES	SN-1420I (U.S. Patent #7202405)
HEADS	REMO Coated (A)

SERIES COMPONENT

Professional, Session Series

President, Decade Series

Professional Series

Professional Series Snare Drums are an exceptional avenue for the gigging pro. Their EvenPly shell fuses six reduced thickness layers of cross-laminated North American Maple for expanded tonal purity, increased resonance, and dramatically different snare sensitivity.



President Series

Traditionally full and controlled, President Series Deluxe Snare drums capture the essence of Pearl's unique drum making beginnings. Each drum utilizes Pearl's original wood snare drum format, including Lauan 6-ply shell, rounded 45 degree edges, eight dual "Battleship" lugs, and adjustable internal muffler for a singular, modern-classic feel and sound.



PMX1450S/C



PMX1465S/C

PMX1450S/C 14" x 5"	
SHELL	EvenPly-Six (5.4 mm) Maple
HOOPS	SuperHoop II (SH-1410 / 1410S)
LUGS	CL-55
RODS	T-062 (20)
STRAINER	SR-017
SNARES	S-022N
HEADS	REMO UT Coated (A)

PMX1465S/C 14" x 6.5"	
SHELL	EvenPly-Six (5.4 mm) Maple
HOOPS	SuperHoop II (SH-1410 / 1410S)
LUGS	CL-65
RODS	T-061L (20)
STRAINER	SR-017
SNARES	S-022N
HEADS	REMO UT Coated (A)



PSD1455SE/C



PSD1455SE/C

PSD1455SE/C 14" x 5.5"	
SHELL	6 ply (7.5mm) Lauan
HOOPS	SuperHoop II (SH-1408 / 1408S)
LUGS	BSL-55
RODS	T-062 (16)
STRAINER	SR-17A / SR-150E
SNARES	SN-1420I (U.S. Patent #7202405)
HEADS	REMO UT CS Black Dot Clear
INSIDE MUFFLER	IM-100W

Session Studio Select Series

Session Studio Select snare drums are a true complement to today's rapidly shifting musical landscape. Their thin, 5.4mm EvenPly-Six combination of Masters-grade Birch and African Mahogany yields a blend of pre-EQ'd clarity, warmth, and controlled punch. Tonally sophisticated in feel, look, and performance.



Decade Maple Series

Built to push the boundaries of performance and price, the 6-ply lacquered Maple shell featured in Decade Series snares pack a serious punch. Excellent for elevating your evolving sound to the next level.



STS1455S/C



STS1465S/C

STS1455S/C 14" x 5.5"	
SHELL	EvenPly-Six (5.4mm) Birch / African Mahogany
HOOPS	SuperHoop II (SH-1410 / 1410S)
LUGS	CL-55
RODS	T-062 (20)
STRAINER	SR-017
SNARES	S-022N
HEADS	REMO UT Coated (A)

STS1465S/C 14" x 6.5"	
SHELL	EvenPly-Six (5.4mm) Birch / African Mahogany
HOOPS	SuperHoop II (SH-1410 / 1410S)
LUGS	CL-65
RODS	T-061L (20)
STRAINER	SR-017
SNARES	S0-22N
HEADS	REMO UT Coated (A)



DMP1455S/C

DMP1455S/C 14" x 5.5"	
SHELL	EvenPly-Six (5.4 mm) Maple
HOOPS	1.6mm Steel (RH-1408 / 1408S)
LUGS	NDL-55/C
RODS	TR-5052 (16)
STRAINER	SR-700
SNARES	SNW-1420
HEADS	REMO UT Coated (A)

FREE FLOATING

TASK-SPECIFIC INNOVATION Pearl's unique Free Floating Snare chassis removes all hardware from the shell to greatly improve resonance and projection.



By combining the tonal character of each shell type with its ideally matched depth, each Free Floating snare drum is engineered to fit a specific task by model and gives you a unique voice for any sonic situation.

The Ultimate Purity Of Sound

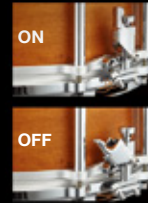

CLICK-LOCK THROW-OFF SYSTEM Engineered with Polymer bearings for precise and smooth action. Unique nylon grip mechanism locks the snares into place. (U.S. Patent 9082376)

SENSITONE HERITAGE ALLOY

Legendary Snare Tone from Studio to Stage

The Sensitone sound has always been drawn from an amalgamation of The Heritage Alloys (Aluminum, Black-over-Brass, and Steel) for the necessary, immediate tones of yesterday's chart toppers with an undeniably modern sensibility. Sensitone Heritage Alloy snare models employ these three original metal shell types to deliver essential tone and power with the right gig-ready touches.



Deep, rich snare power with short, even sustain decay.
FTAL1480



Ultimate in throaty, deep snare growl. Shortened decay.
FTMH1480

FTAL1480	14" x 8"
SHELL	1.2mm Seamless Aluminum
HOOPS	MasterCast (DC-1410 / DC-1410S)
LUGS	FT-80
RODS	SST-5042 (20)
STRAINER	S-R160F (U.S. Patent 9082376)
SNARES	SN-1442C (U.S. Patent #7202405)
HEADS	REMO Coated (A)

FTMH1480	14" x 8"
SHELL	8 ply (10mm) African Mahogany
HOOPS	MasterCast (DC-1410 / D-C1410S)
LUGS	FT-80
RODS	SST-5042 (20)
STRAINER	SR-160F (U.S. Patent 9082376)
SNARES	SN-1442C (U.S. Patent #7202405)
HEADS	REMO Coated (A)



Lower overtone body, preserves crisp top-end snare snap.
FTPB1465



Full, rounded bottom frequencies. Extra midrange body.
FTMMH1465

FTPB1465	14" x 6.5"
SHELL	1.2mm Phosphor Bronze
HOOPS	MasterCast (DC-1410 / DC-1410S)
LUGS	FT-65
RODS	SST-5042 (20)
STRAINER	SR-160F (U.S. Patent 9082376)
SNARES	SN-1420C (U.S. Patent #7202405)
HEADS	REMO Coated (A)

FTMMH1465	14" x 6.5"
SHELL	6 ply (7.5mm) (4 ply Maple w/2 ply Inner African Mahogany)
HOOPS	MasterCast (DC-1410 / DC-1410S)
LUGS	FT-65
RODS	SST-5042 (20)
STRAINER	SR-160F (U.S. Patent 9082376)
SNARES	SN-1420C (U.S. Patent #7202405)
HEADS	REMO Coated (A)



Full-spectrum, both bright in punch and warm in tone.
FTBR1450



Punchy and smooth. A perfect "go-to" snare.
FTMM1450

FTBR1450	14" x 5"
SHELL	1mm Brass
HOOPS	MasterCast (DC-1410 / DC-1410S)
LUGS	FT-50
RODS	SST-5042 (20)
STRAINER	SR-160F (U.S. Patent 9082376)
SNARES	SN-1420I (U.S. Patent #7202405)
HEADS	REMO Coated (A)

FTMM1450	14" x 5"
SHELL	6 ply (7.5mm) Maple
HOOPS	MasterCast (DC-1410 / DC-1410S)
LUGS	FT-50
RODS	SST-5042 (20)
STRAINER	SR-160F (U.S. Patent 9082376)
SNARES	SN-1420I (U.S. Patent #7202405)
HEADS	REMO Coated (A)



1mm shell for bright, open attack with ringy overtone.
FTSS1435



Dense all Birch shell delivers bright, open attack.
FTBB1435

FTSS1435	14" x 3.5"
SHELL	1mm Stainless Steel
HOOPS	MasterCast (DC-1410 / DC-1410S)
LUGS	FT-35
RODS	SST-5035 (20)
STRAINER	SR-160F (U.S. Patent 9082376)
SNARES	SN-1420D (U.S. Patent #7202405)
HEADS	REMO Coated (A)

FTBB1435	14" x 3.5"
SHELL	6 ply (5.4mm) Birch
HOOPS	MasterCast (DC-1410 / DC-1410S)
LUGS	FT-35
RODS	SST-5035 (20)
STRAINER	SR-160F (U.S. Patent 9082376)
SNARES	SN-1420D (U.S. Patent #7202405)
HEADS	REMO Coated (A)



Dry, focused crack with quick decay.
STH1450AL



Full, guttural snare bellow with little overtone.
STH1465AL

STH1450AL	14" x 5"
SHELL	1.2mm Beaded Aluminum
HOOPS	SuperHoop II (SH-1410 / 1410S)
LUGS	CL-55
RODS	T-061L (20)
STRAINER	SR-017
SNARES	SN-1420I (U.S. Patent #7202405)
HEADS	REMO Coated (A)

STH1465AL	14" x 6.5"
SHELL	1.2mm Beaded Aluminum
HOOPS	SuperHoop II (SH-1410B / 1410S)
LUGS	CL-65
RODS	T-061L (20)
STRAINER	SR-017
SNARES	SN-1420I (U.S. Patent #7202405)
HEADS	REMO Coated (A)



Perfect blend of attack and brassy body.
STH1450BR



An elegant solution for punch and warmth.
STH1465BR

STH1450BR	14" x 5"
SHELL	1mm Beaded Black Nickel/Brass
HOOPS	SuperHoop II (SH-1410B / 1410S)
LUGS	CL-55
RODS	T-061L (20)
STRAINER	SR-017
SNARES	SN-1420I (U.S. Patent #7202405)
HEADS	REMO Coated (A)

STH1465BR	14" x 6.5"
SHELL	1mm Beaded Black Nickel/Brass
HOOPS	SuperHoop II (SH-1410B / 1410S)
LUGS	CL-65
RODS	T-061L (20)
STRAINER	SR-017
SNARES	SN-1420I (U.S. Patent #7202405)
HEADS	REMO Coated (A)



Crisp, sensitive high-pitched snap.
STH1450S



Belting crack with mild midrange overtone.
STH1465S

STH1450S	14" x 5"
SHELL	1mm Beaded Steel
HOOPS	SuperHoop II (SH-1410B / 1410S)
LUGS	CL-55
RODS	T-061L (20)
STRAINER	SR-017
SNARES	SN-1420I
HEADS	REMO Coated (A)

STH1465S	14" x 6.5"
SHELL	1mm Beaded Steel
HOOPS	SuperHoop II (SH-1410B / 1410S)
LUGS	CL-65
RODS	T-061L (20)
STRAINER	SR-017
SNARES	SN-1420I
HEADS	REMO Coated (A)

THE SR017 STRAINER

Simple and effective, the SR017 is a Pearl standard for effortless snare switching and sensitivity control. Its smooth lever action and fine-tuning knob let you dial in the right amount of snare wire saturation to suit your personal sound.



SIGNATURE SNARES

Capturing The Exclusive Sound of Drumming Legends

Discover the artist-curated sound that inspired these marquee Pearl players. Each Signature Series snare drum was painstakingly designed by the drummer whose name it bears. This not only shares an element of their sound with you, but gives you the freedom to truly make it your own.



DENNIS CHAMBERS



DC1465S 14" x 6.5"

SHELL	4 ply Maple w/ 4ply Re-Rings
HOOPS	MasterCast(DC-1410/DC-1408S)
LUGS	STL-100
RODS	SST-5047
STRAINER	SR-300
SNARES	S-051 (x3) Snappy Wire Snares
HEADS	(Evans) B14G12 / S14H30
FINISH	#119 Matte Black Lacquer

A Snare Fit for a Legend, Truly in a Class By Itself.



JOEY JORDISON



JJ1365N 13" x 6.5"

SHELL	1 mm Steel
HOOPS	SuperHoop II (SHB-1308B / 1308S)
LUGS	CL-65B
RODS	SST-5047 (16)
STRAINER	SR-017B
SNARES	S-029N
HEADS	REMO Coated (A)
FINISH	Matte Black Lacquer

A Fierce, Ferocious, Fast Snare fit for a Metal Drumming Legend.



MATT HALPERN



MH1460/B 14" x 6"

SHELL	1.5 mm Brass
HOOPS	MasterCast(DCB-1410 / 1410S)
LUGS	STL-55LMH/B
RODS	SST-5052 (20)
STRAINER	SR-150B (U.S. Patent 9082376)
SNARES	SN-1420I (U.S. Patent #7202405)
HEADS	Evans Heavyweight Dry
FINISH	Matte Black Lacquer

A Snare Drum from the Outer Limits of the Edge.



MATT MCGUIRE



MM1465S/C 14" x 6.5"

SHELL	1 mm Steel
HOOPS	SuperHoop II (SH-1410 / 1410S)
LUGS	CL-65
RODS	T-061 (20)
STRAINER	SR-017
SNARES	SN-1420I (U.S. Patent #7202405)
HEADS	Evans Power Center
FINISH	Matte Black Lacquer

Introducing The World's First "SMART" Snare Drum.



BRIAN FRASIER-MOORE



BFM1455S/C 14" x 5.5"

SHELL	12ply(15mm) Gumwood/Maple/Gumwood
HOOPS	MasterCast(DC-1410 / 1410S)
LUGS	CL-55
RODS	T-062 (20)
STRAINER	SR-150 (U.S. Patent 9082376)
SNARES	SN-1442I (U.S. Patent #7202405)
HEADS	Evans Power Center
FINISH	Gloss Gumwood Natural Burst

A Truly Inspiring Snare Drum.



OMAR HAKIM



OH1350 13" x 5"

SHELL	6 ply (7.5mm) African Mahogany
HOOPS	SuperHoop II (SH-1308 / 1308S)
LUGS	CL-55
RODS	SST-5047 (16)
STRAINER	SR-150 (U.S. Patent 9082376)
SNARES	S-029N
HEADS	REMO Coated (A)
FINISH	#140 Natural Mahogany

A "Power Piccolo" for a Sonic Blend of Power, Projection and Tonal Color.



IAN PAICE



IP1465 14" x 6.5"

SHELL	1 mm Beaded Steel
HOOPS	SuperHoop II (SH-1410 / 1410S)
LUGS	TB-65
RODS	SST-5042 (20) w/ Tension Rod Lock Nuts
STRAINER	SR-017
SNARES	S-022N
HEADS	REMO Coated (A)
FINISH	Chrome

A Timeless, Innovative Collaboration with a True Rock Legend.

HYBRID EXOTIC & ULTRA CAST

SPACE AGED PRECISION THROUGH ADVANCED SNARE CRAFTING.

For the ultimate in power and prestige, Pearl's Ultracast Aluminum Snares and limited Hybrid Exotic models offer stark, head-turning voices that stick out from the crowd.



Quick, yielding snap with heavy midrange overtones.
HEP1450

HEP1450	14" x 5"
SHELL	VectorCast
HOOPS	SuperHoop II (SH-1410 / 1410S)
LUGS	STL-100
RODS	SST-5047 (20)
STRAINER	SR-1000 (U.S. Patents #7220905 #7365256)
SNARES	SN-1420C (U.S. Patent #7202405)
HEADS	REMO Coated (A)



UCA1450/B



UCA1465/B

UCA1450/B	14" x 5"
SHELL	3mm Cast Aluminum w/ Reinforcement
HOOPS	SuperHoop II (SHB-1410 / 1410S)
LUGS	TB-50B
RODS	SST-5042 (20)
STRAINER	SR-1000B (U.S. Patents #7220905 #7365256)
SNARES	SN-1420C (U.S. Patent #7202405)
HEADS	Remo Coated (A)

UCA1465/B	14" x 6.5"
SHELL	3mm Cast Aluminum w/ Reinforcement
HOOPS	SuperHoop II (SHB-1410 / 1410S)
LUGS	TB-65B
RODS	SST-5042 (20)
STRAINER	SR-1000B (U.S. Patents #7220905 #7365256)
SNARES	SN-1420C (U.S. Patent #7202405)
HEADS	Remo Coated (A)



STAVECRAFT

A startling addition to any pro drummer's soundscape, each StaveCraft shell starts from two layers of meticulously beveled solid wood staves. Dado-Loc, an old world principal exclusive to these snares, inserts a solid segment of contrasting wood into the center Dado channel formed by each stave. This solid fusion of hardwoods is lathed to a perfectly round 25mm thickness for unparalleled volume and power.



Peak high-end sonic dominance with lively overtone.
SCD1450AW



Dense, strident snare power with full-compass swagger.
SCD1465AW

SCD1450AW	14" x 5"
SHELL	25mm Dual Ash Wood Stave w/ Makha DadoLoc
HOOPS	MasterCast (DC-1410 / 1410S)
LUGS	STL-55L
RODS	SST-5042 (20)
STRAINER	SR-150 (U.S. Patent 9082376)
SNARES	SN-1420I (U.S. Patent #7202405)
HEADS	Remo USA CS Black Dot Clear

SCD1465AW	14" x 6.5"
SHELL	25mm Dual Ash Wood Stave w/ Makha DadoLoc
HOOPS	MasterCast (DC-1410 / 1410S)
LUGS	STL-65
RODS	SST-5042 (20)
STRAINER	SR-150 (U.S. Patent 9082376)
SNARES	SN-1420I (U.S. Patent #7202405)
HEADS	Remo USA CS Black Dot Clear



Quick, tight high-range tonal power.
SCD1450TO



Sensitive, centered low-overtone drive.
SCD1465TO

SCD1450TO	14" x 5"
SHELL	25 mm Dual Thai Oak Stave w/ Makha DadoLoc
HOOPS	MasterCast (DC-1410 / 1410S)
LUGS	STL-55L
RODS	SST-5042 (20)
STRAINER	SR-150 (U.S. Patent 9082376)
SNARES	SN-1420I (U.S. Patent #7202405)
HEADS	Remo USA CS Black Dot Clear

SCD1465TO	14" x 6.5"
SHELL	25 mm Dual Thai Oak Stave w/ Makha DadoLoc
HOOPS	MasterCast (DC-1410 / 1410S)
LUGS	STL-65
RODS	SST-5047 (20)
STRAINER	SR-150 (U.S. Patent 9082376)
SNARES	SN-1420I (U.S. Patent #7202405)
HEADS	Remo USA CS Black Dot Clear

DUOLUXE

THE WORLD'S FIRST INLAID BRASS SNARE DRUM

Pearl celebrates three-quarters of a century of iconic drum sounds with Duoluxe, a modern take on our legendary Jupiter snare drum. This classic combination of a chrome-over-brass alloy shell and our trademark dual inverted shell beads is augmented with two finish bands of Nicotine White Marine Pearl inlay. This gives the shell a singular look and adds tonal nuance to its unbridled sound.



Bold and crisp with short midrange overtone.
DUX1450BR



Fierce and centered mid-to-low sustain.
DUX1465BR

DUX1450BR	14" x 5"
SHELL	1mm Dual-Beaded Brass / Chrome
HOOPS	SuperHoop II (SH-1410 / 1410S)
LUGS	BSL-55
RODS	SST-5042 (20)
STRAINER	SR-17A / SR-150E
SNARES	SN-1420I (U.S. Patent #7202405)
HEADS	REMO Coated (A)
FINISH	INLAY: #405 Nicotine White Marine Pearl (x2)

DUX1465BR	14" x 6.5"
SHELL	1mm Dual-Beaded Brass / Chrome
HOOPS	SuperHoop II (SH-1410 / 1410S)
LUGS	BSL-55
RODS	SST-5055 (20)
STRAINER	SR-17A / SR-150E
SNARES	SN-1420I (U.S. Patent #7202405)
HEADS	REMO Coated (A)
FINISH	INLAY: #405 Nicotine White Marine Pearl (x2)



Cracking tonal pop with short midrange hum.
SCD1450MK



Thick, cavernous sonic body with cutting punch.
SCD1465MK

SCD1450MK	14" x 5"
SHELL	25 mm Dual Makha Stave w/ Thai Oak DadoLoc
HOOPS	MasterCast (DC-1410 / 1410S)
LUGS	STL-55L
RODS	SST-5042 (20)
STRAINER	SR-150 (U.S. Patent 9082376)
SNARES	SN-1420I (U.S. Patent #7202405)
HEADS	Remo USA CS Black Dot Clear

SCD1465MK	14" x 6.5"
SHELL	25 mm Dual Makha Stave w/ Thai Oak DadoLoc
HOOPS	MasterCast (DC-1410 / 1410S)
LUGS	STL-65
RODS	SST-5047 (20)
STRAINER	SR-150 (U.S. Patent 9082376)
SNARES	SN-1420I (U.S. Patent #7202405)
HEADS	Remo USA CS Black Dot Clear

UTILITY

VERSATILE DRUMS FOR SECONDARY EFFECTS

MODERN UTILITY snare drums are vital instruments. Well-appointed tools of the trade crafted for the informed, current drummer to make the gig great. Priced for the active working player, Modern Utility snares are available in both 100% Maple and Beaded Steel. Flexible enough to add to any setup and strong enough to stand up to constant play, each model has a cool, versatile vibe. Featuring our CL arch lugs and smooth SR700 snare strainer for precise tunability.



See Korn drummer Ray Luzier's performance test of each Modern Utility snare at



MUS1480M/C



MUS1410FM/C



Leg Brackets:
FTB07 (x3)



MUS1455M/C



MUS1465M/C



MUS1350M/C



MUS1270M/C

MUS1480M		14" x 8"
SHELL	6 ply (5.4mm) Maple	
HOOPS	1.6mm Steel (RH-1408 / 1408S)	
LUGS	CL-100	
RODS	TR-5047 (16)	
STRAINER	SR-700	
SNARES	SNW-1420	
HEADS	REMO UT Coated (A)	
FINISH	#224 Matte Natural, #227 Satin Black	

MUS1410FM		14" x 10"
SHELL	6 ply (5.4mm) Maple	
HOOPS	1.6mm Steel (RH-1408 / 1408S)	
LUGS	CL-100	
RODS	TR-5047 (16)	
STRAINER	SR-017	
SNARES	SNW-1420	
HEADS	REMO UT Coated (A) w/Ring Mute	
FINISH	#220 Satin Brown	

MUS1455M		14" x 5.5"
SHELL	6 ply (5.4mm) Maple	
HOOPS	1.6mm Steel (RH-1408 / 1408S)	
LUGS	CL-55	
RODS	TR-5052 (16)	
STRAINER	SR-700	
SNARES	SNW-1420	
HEADS	REMO UT Coated (A)	
FINISH	#224 Matte Natural, #227 Satin Black	

MUS1465M		14" x 6.5"
SHELL	6 ply (5.4mm) Maple	
HOOPS	1.6mm Steel (RH-1408 / 1408S)	
LUGS	CL-65	
RODS	TR-5047 (16)	
STRAINER	SR-700	
SNARES	SNW-1420	
HEADS	REMO UT Coated (A)	
FINISH	#224 Matte Natural, #227 Satin Black	

MUS1350M		13" x 5"
SHELL	6 ply (5.4mm) Maple	
HOOPS	1.6mm Steel (RH-1308 / 1308S)	
LUGS	CL-55	
RODS	TR-5047 (16)	
STRAINER	SR-700	
SNARES	SNW-1316	
HEADS	REMO UT Coated (A)	
FINISH	#224 Matte Natural, #227 Satin Black	

MUS1270M		12" x 7"
SHELL	6 ply (5.4mm) Maple	
HOOPS	1.6mm Steel (RH-1206 / 1206SL)	
LUGS	CL-65	
RODS	TR-5057 (12)	
STRAINER	SR-700	
SNARES	SNW-1216	
HEADS	REMO UT Coated (A)	
FINISH	#224 Matte Natural, #227 Satin Black	

EFFECTS SNARES



M1060 10" x 6"

SHELL	6 ply (7.5mm) Maple
HOOPS	SuperHoop II (SH-1006 / 1006S)
LUGS	CL-65
RODS	SST-5047 (12)
STRAINER	SR-018
SNARES	S-032N
HEADS	REMO Coated (A)
FINISH	#114 Liquid Amber



M1270 12" x 7"

SHELL	8 ply (10.0 mm) Maple
HOOPS	1.6mm Steel (RIM-1208B / 1208S)
LUGS	CL-100
RODS	SST-5047 (16)
STRAINER	SR-018
SNARES	S-031N
HEADS	REMO Coated (A)
FINISH	#114 Liquid Amber



SFS1335B 13" x 3.5"

SHELL	Steel
HOOPS	1.6mm Steel
LUGS	MSFL-35
RODS	RSHI-3235
STRAINER	SR-02MSFL/SR-02EMSFL
SNARES	SN-13MSFL
HEADS	JH-13C
FINISH	Matte Black

PICCOLO



B1330 13" x 3"

SHELL	1mm Brass
HOOPS	1.6mm Steel (RIM-1308 / 1308S)
LUGS	CL-05
RODS	T-055 (16)
STRAINER	SR-018
SNARES	S-029N
HEADS	REMO Coated (A)
FINISH	---



S1330B 13" x 3"

SHELL	1mm Steel
HOOPS	1.6mm Steel (RIM-1308 / 1308S)
LUGS	CL-05
RODS	T-055 (16)
STRAINER	SR-018
SNARES	S-029N
HEADS	REMO Coated (A)
FINISH	Black Finish



M1330 13" x 3"

SHELL	6 ply (7.5 mm) Maple
HOOPS	1.6mm Steel (RIM-1308 / 1308S)
LUGS	CL-05
RODS	T-055 (16)
STRAINER	SR-018
SNARES	S-029N
HEADS	REMO Coated (A)
FINISH	#114 Liquid Amber, #102 Natural Maple

FIRECRACKER



FCP1250 12" x 5"

SHELL	8 ply (10.0 mm) Poplar
HOOPS	1.6mm Steel (RIM-1206 / 1206SL)
LUGS	CL-55 (with Steel Nut)
RODS	T-061L (12)
STRAINER	SR-018
SNARES	S-031
HEADS	PTH12C
FINISH	#271 Ebony Mist



FCS1050 10" x 5"

SHELL	Steel
HOOPS	1.6mm Steel (RIM-1006 / 1006S)
LUGS	CL-55 (with Steel Nut)
RODS	T-061L (12)
STRAINER	SR-018
SNARES	S-032
HEADS	PTH10C
FINISH	Chrome Plating

EFFECTS

THE IGNITER To capture the searing energy of drumming for a new generation of players, Pearl collaborated with viral video drummer Casey Cooper to create The Igniter. Specifically created to instantly improve the sound of any student drum kit, it's a fantastic value to keep the fire of drumming burning bright!

CC1450S/C		14" x 5"
SHELL	6 ply (6.8mm) Poplar / Maple	
HOOPS	1.6mm Steel (RH1408 / 1408S)	
LUGS	CL55	
RODS	TR5047 (16)	
STRAINER	SR700	
SNARES	SNW1420	
HEADS	REMO UT Coated (A)	
FINISH	Artisan II Flame Finish	



COLLABORATION CASEY COOPER @COOP3RDRUMM3R

e/TRADITIONAL CONFIGURATION



10", 12" and 14" toms, a 14" snare, and PUREtouch Kick Pad. PUREtouch Cymbals, ICON e-Rack, MDL1 Module.
EM-53T

10", 12" and 14" toms, a 14" snare, and PUREtouch Kick Pad. PUREtouch Cymbals, ICON e-Rack, MDL1 Module + additional 15" CYMBAL PAD, Cymbalholder and Rackclamp.
EM-53TC

e/HYBRID CONFIGURATION

EM-HWP

The foundation of the e/MERGE electronic drum set is a custom designed, chrome plated ICON e-Rack system.



10", 12" and 14" toms, 14" snare, and 18" acoustic bass drum. PUREtouch Cymbals, ICON e-Rack, MDL1 Module.
EM-53HB

10", 12" and 14" toms, a 14" snare, and 18" acoustic bass drum. PUREtouch Cymbals, ICON e-Rack, MDL1 Module + additional 15" CYMBAL PAD, Cymbalholder and Rackclamp.
EM-53HBC

e/MERGE

**NOT JUST A NEW STANDARD.
A NEW SOUND. A NEW FEEL. AND, A
COMPLETELY NEW E-DRUMMING EXPERIENCE.**

e/MERGE is about change, and change in the e-drum market has been way overdue. When we looked closely at every aspect of the current e-drumming experience with KORG, together we knew we could make a dramatic difference. And that difference begins with the all new e/MERGE module. Simple yet elegant in design, the e/MERGE MDL1 module features a full library of high definition, natural, organic and minimally processed acoustic Pearl drums. We then added the very best electronic, world, orchestral and specialty percussion sounds from KORG's vast library of pristine quality samples. But, the module is only part of the change.

There are three key elements that separate e/MERGE from anything that has come before. The MDL1 e/MERGE Module, KORG's amazing WAVE TRIGGER TECHNOLOGY and Pearl's acoustic-like PUREtouch electronic pads and cymbals combine to create an exceptional e-drumming experience.

MDL-1



e/MERGE MDL-1 MODULE Simple, straight forward yet extremely powerful, the MDL-1 module offers, a pair of powerful multicore processors, a full library of acoustic Pearl drums recorded in one of the world's most renowned studios, pristine samples from KORG's library and the variety of routing options every e-drummer needs.



WAVE TRIGGER TECHNOLOGY



WAVE TRIGGER TECHNOLOGY This ultra-fast and highly sensitive technology partially based upon KORG's groundbreaking Wave Drum allows even your stick choice to make a discernible difference in the sound of your drum. Wave Trigger Technology speed adds a realism to the playing experience never before available to the e-drummer.

PUREtouch

PUREtouch PADS & CYMBALS Perfectly sized pads designed to replicate the ultimate acoustic-like response. PUREtouch features layer upon layer of specially designed materials each selected for a specific quality that together create an e-experience never before possible.

MODULE SPECIFICATIONS



SOUND GENERATOR	2 CPU (4 core + 2 core)
POLYPHONY	128 Voices
VOICE	700 HD Sound Library
DRUM KIT	35 HD Kits
EFFECTS	36
SONG RECORDING TYPE	44.1kHz, 16 Bit WAV
SONG RECORDING TIME	Approximately 12 Hours
CLICK TEMPO	30 - 300BPM
BEAT	1/2 - 24/2, 1/4 - 24/4, 1/8 - 24/8, 1 - 24/8T, 1/16 - 24/16 (T=Triplet)
CLICK VOICES	10
CONTROLLERS	Knobs and Ambient Slider Control
DISPLAY	3.25" x 1" Graphic LCD
CONNECTORS	Master Out L/Mono & R Direct Out (8) Headphones Out Aux In TRS Mini Main Trigger inputs (DB-25 Connector) Accessory Inputs (3)
MIDI	USB to PC Port (Transport USB Audio & MIDI Data) USB-A (for WAV files and Settings Data)
POWER SUPPLY	MIDI Output
DIMENSIONS, WEIGHT	100-120V, 50-60Hz, Switching Power Supply 2.2lbs, 9" W x 7.5" D x 2" H

MIMIC PRO

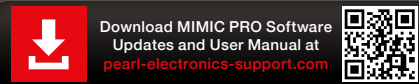

Powered by Slate



MIMP24B

MIMIC PRO POWERED BY SLATE

STATE OF THE ART FEATURES:

- 7" IPS Touch Screen with Programmable Data Wheel
- 120GB Solid State drive
- 16 Dual Zone Inputs
- 16 Programmable Audio Outputs
- MIDI In and Out
- High Quality Digital to Analog Converters
- Two completely separate mixers for headphone and Main outs (Drummer gets a personal mix with and without effects independent of Main outputs)
- Import Wave, Aiff or MP3 sound files
- Compatible with most pads on the market
- Steven Slate Drums 5 Library
- 24 bit multi channel sample library with separate adjustment of Close, Overhead and Room mics
- Onboard effects include EQ, Compression, Reverb with Room Sizes
- Individual Cymbal Volume Adjustments for Bell, Bow, Edge, Chik and Splash
- All AUX and Cymbal inputs have choke function
- Supports triple and dual zone cymbals and dual zone hi hat
- SD card slot and USB
- Additional Instruments and Libraries will be available
- Stereo Aux In and Onboard Metronome
- Internal Recording for Loops and/or Performances

**THE MOST AMAZING
DRUM MODULE
THE WORLD HAS
EVER KNOWN.**

**SERIOUSLY,
IT'S THAT GOOD.**



Superior sound, accurate triggering and connectivity are the most important features of a drum module. Pearl Drums and Steven Slate have joined forces to create "Mimic Pro" - the world's most advanced percussion sound source for studio and live performance applications.

At the heart of this ground breaking unit is the new Steven Slate 5 drum library that features multi-channel drum samples recorded in world class studios. Each instrument supports adjustment of Attack, Sustain, Release, Tune, Pan and volume. Instead of substituting digital effects to create ambience, these instruments use the actual ambient recordings with separate adjustment of close, overhead and room mics.

Mimic Pro is the first drum module to implement a 7" IPS touch screen and the first to offer 2 mixers for independent headphone and front house outputs. Now that the drummer is responsible for triggering loops and other sounds for a performance, Mimic Pro can import audio files to trigger from your pads.

Storage is no longer a problem with Mimic's 120GB Solid State Drive and lightning fast loading time. Speaking of connectivity, Mimic Pro is compatible with Pearl TruTrac pads and a host of pads from other manufacturers. Top that off with sixteen audio outs, 16 Trigger inputs, independent SD card Slot, USB and Midi In & Out, Stereo Aux input and you would be hard pressed to find a better option for today's musician.



malletSTATION

The World's First 3.0 Octave Adjustable Range
Electronic Mallet Controller

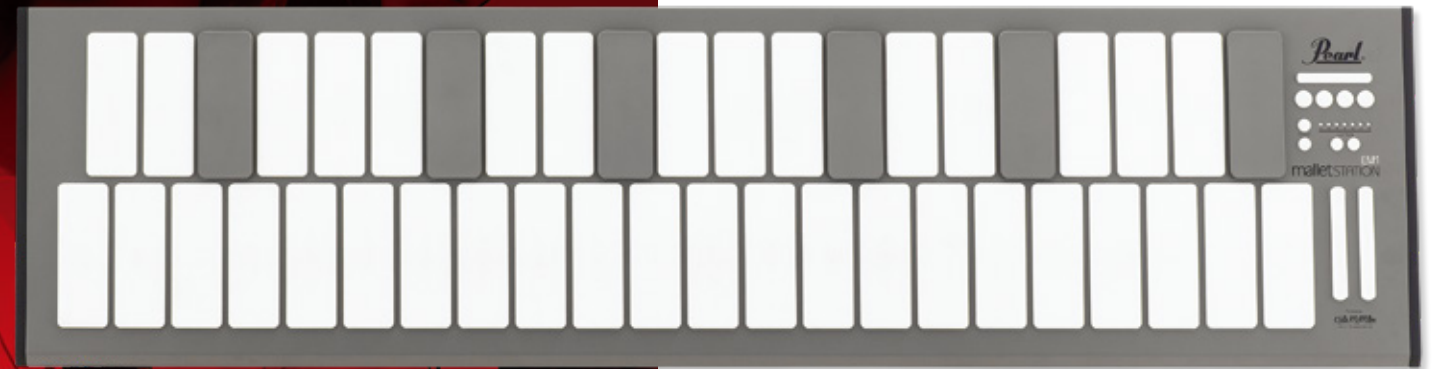

EM-1

malletSTATION™

PRACTICE, PERFORM, COMPOSE ANYWHERE.

- USB Powered MIDI Mallet Keyboard Controller
- Universal Compatibility through phone/tablet/laptop
- Tech-Forward Design featuring KMI Smart Fabric Sensors
- Low Note, Adjustable, User defined
- Customizable mallet dampening and aftertouch modes for realistic performance techniques
- Natural feeling soft silicone keys, all-weather playing surface
- Assignable buttons and faders for customized control and functions
- Three assignable pedal inputs for expression and sustain
- Hybrid Aluminum and Steel Chassis design for durability and stability
- Optional MIDI Expander to use external MIDI Hardware (sold separately)
- Flexible mounting on desktop, X-stand, or module mounts (sold separately)
- Mounting plates, stands, cases, covers, and other peripherals (available separately)

- 43, 1.75" x 5" soft silicone keys
- 3 faders and 4 buttons, MIDI assignable
- 3 MIDI assignable 1/4" pedal inputs
- Bottom Note Range Shift up/down buttons
- Octave up/down buttons
- 1.6" H x 12.6" W x 49" L
- 22.5 lbs



Shown Mounted on Vibraphone with Field Frame



Sleek, modern design with an ultra thin 1.6" profile

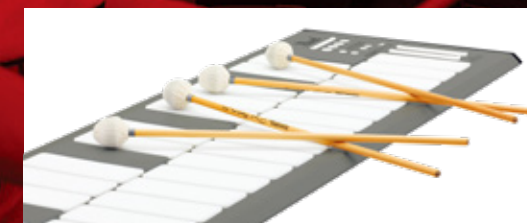

1.75" x 5" Soft Silicone Keys powered by KMI Smart Fabric Sensor Technology

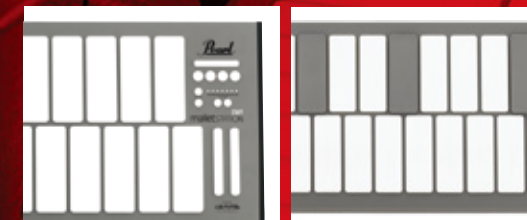

Software Assignable Control Panel with 3 Faders, 4 Buttons, plus Low Note and Octave Shift (U.S. Patent 10311841)

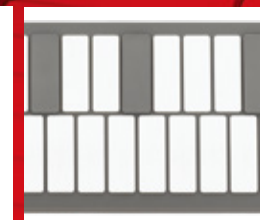

Moveable Accidental "Gap Caps" for visual cues when low note range is adjusted



Jack panel with USB MIDI, MIDI expander port, and 3 MIDI assignable 1/4" pedal inputs



Optional Dual Module Mounts allow malletSTATION to easily mount on racks, stands, and field frames

Pearl once again redefines the electronic percussion experience by introducing the revolutionary EM-1 malletSTATION adjustable range electronic mallet controller.

The EM-1 malletSTATION is a 3.0 octave adjustable range electronic mallet controller designed for all levels of player, from the beginning student through the gigging professional. The adjustable range function allows you to set the fundamental diatonic note of the instrument to what you need—low D xylophone? No problem! Powered exclusively by USB Bus Power, the malletSTATION is designed to be used with Mac, PC, iPad, iPhone, and Android devices, making it the first truly portable mallet percussion controller on the market.

Designed in collaboration with Keith McMillen Instruments, malletSTATION's tech-forward design features KMI's Smart Fabric Sensor technology allowing the silicone bar material to have an extremely sensitive, natural response, including mallet dampening and aftertouch control, and all can be easily tailored to your individual playing style. The EM1 features a master control section, with 3 programmable faders, 4 programmable buttons, and the fixed function low note and octave shift buttons. In addition, three assignable pedal inputs allow for flexibility in performance such as sustain, expression, or any MIDI parameter of your choice. These controls are fully programmable through a software editor so changing your configuration is as easy as clicking a mouse.

This is the controller that will grow with you throughout your playing career—from music apps on your phone or tablet, to professional digital audio workstations and sound libraries—your sounds and even the instruments you play are only limited by the software you run.

DRUM PEDALS



ELIMINATOR DEMON XR

The Ultimate In Speed,
Rebound, And Accuracy.



SEE the **Demon XR** in action
with design partner George
Kollias and John Longstreth



ENHANCED REBOUND STROKE
Eases High Tempo Single
and Double Strokes



DIRECT DRIVE
Extreme Speed and Precise,
Resistance-Free Playability



SLEEK LONGBOARD
Improves Double Stroke Response

**MACHINED ALUMINUM
CONSTRUCTION**
Delivers Light,
Efficient Action

Single Pedal Complete
P-3500D

THE DIRECT-DRIVE TRIPLE THREAT: X-TREME SPEED, X-TREME REBOUND, X-TREME ACCURACY.

Developed in conjunction with the world's top drumming talents for speed and enhanced rebound in extreme musical situations, The Pearl Demon XR Bass Drum Pedal is your direct path to rapid fire bass drum performance.

Delivering the ultimate in Speed, Rebound, and Accuracy, the Pearl Demon XR (for X-treme Response) Bass Drum Pedal is a true Triple Threat in bass drum pedal performance.

P-3500D BASS DRUM PEDAL

DRIVE	Direct Drive
FOOT BOARD	Longboard Machined Aluminum
DRIVE BEARINGS	NiNJA Low-Friction Extreme High-Tension Spring (Normal Spring included)
SPRING	X-Treme Impact Beater (B-350XR)
BEATER	Click-Lock
TENSION ADJUSTMENT	Included
CASE	Pivoting Hoop Clamp
HOOP CLAMP	Included

P-3502D DOUBLE BASS DRUM PEDAL

DRIVE	Direct Drive
FOOT BOARD	Longboard Machined Aluminum
DRIVE BEARINGS	NiNJA Low-Friction Extreme High-Tension Spring (Normal Spring included)
SPRING	X-Treme Impact Beater (B-350XR)
BEATER	Click-Lock
TENSION ADJUSTMENT	Included
CASE	Pivoting Hoop Clamp
HOOP CLAMP	Included
UNIVERSAL JOINT	Z-Link Drive Shaft



Z-LINK
Universal Linkage



X-TREME IMPACT BEATER
Sharp Attack and Low End

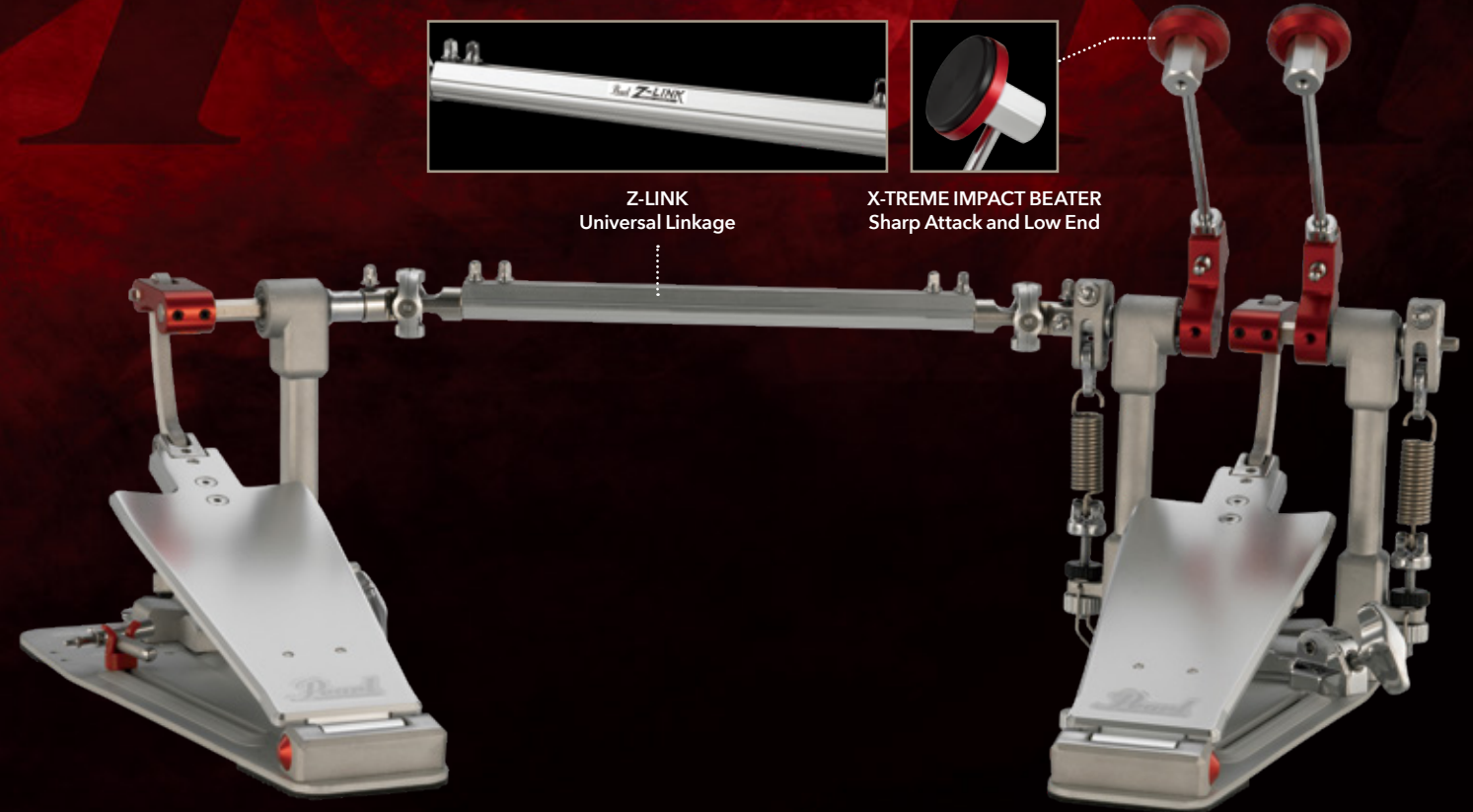

Double Pedal Complete
P-3502D



X-TREME SPEED

Its streamlined machine shop design is the result of a two-year research and development project with drummer George Kollias, and delivers a faster, smoother stroke in action.



X-TREME REBOUND

The key to higher playing speed is in its enhanced rebound action and interchangeable Extreme Spring. This exclusive feature makes repeated strokes in the most extreme musical situations effortless.

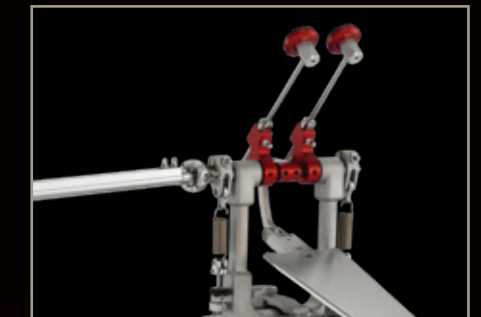

X-TREME ACCURACY

Primed for the high tempo technicality, the Pearl Demon XR is perfect for any drumming style where precision and endurance is key.

DEMON PEDALS

The Fastest, Smoothest, Most Powerful Pedals in the World

DEMON DRIVE UNLEASH THE DEMON

Demon Drive's lightning fast power and silky smooth finesse make it the choice of the drumming world's most prolific players. Featuring an amazing array of adjustable features, from beater angle, traction plate grip, and footboard height and angle, Demon Drive truly becomes an extension of your body. Its totally modular design makes it configurable in a variety of single and double pedal setups. Unleash the Demon and find out what custom feel is all about.



U.S. Patent #7579540

A choice of 2 positions for a finesse or power feel. Simply loosen the clamshell to change position.

- Single Pedal Complete P-3000D
- Double Pedal Complete (right footed) P-3002D
- Double Pedal Conversion Kit (right footed) P-3001D
- Double Pedal Complete (left footed) P-3002DL

- Demon Drive (Shown in Shortboard Set Up) P-3000D

Demon Drive (Shown in Shortboard Set Up) P-3000D

CONTROL CORE BEATERS

INDEPENDENT BEATER ANGLE AND FOOTBOARD HEIGHT ADJUSTMENTS

ADJUSTABLE TRACTION PLATE

Direct Drive Double Pedal (Shown in Longboard Setting) P-3002D

P-3000D / P-3002D DEMON DRIVE

DRIVE	Direct Drive
FOOT BOARD	Duo-Deck Convertible
DRIVE BEARINGS	NiNJA Low-Friction
BEATER	Control Core
TENSION ADJUSTMENT	Click-Lock
FOOTBOARD ANGLE	Infinitely Adjustable
BEATER ANGLE	Infinitely Adjustable
CASE	Included
HOOP CLAMP	Pivoting Hoop Clamp

DUO-DECK FOOTBOARD

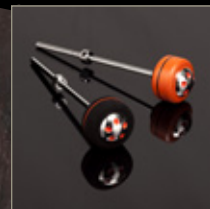

CONTROL CORE BEATER w/ Control Core Elastomer Center. Reduces impact vibration. (U.S. Patent #7626108)

NiNJA



NiNJA BEARINGS Designed for Pro Skateboarding, each bearing features micro-polished balls for minimal friction and unmatched speed.



DIRECT LINK

Dual position adjustment for LIGHT or HEAVY feel, creating a seamless link between your foot and the bass drum.



CLICK-LOCK

Secures spring tension in high impact play. (U.S. Patent #7754953)



DUO-DECK FOOTBOARD

The world's first convertible footboard can switch from a traditional shortboard to a longboard pedal in seconds. (U.S. Patent #7626107)

ELIMINATOR DEMON PEDALS

HEAVENLY FEEL... WICKEDLY FAST

DEMON CHAIN TRADITIONAL FEEL AND POWER OF A CHAIN

An innovative combination of Demon Drive speed and traditional chain drive feel, the Demon Chain's Perfect Circle cam delivers smooth, consistent response throughout the stroke for pinpoint accuracy and control. A high performance package for the driven power drummer.

PERFECT CIRCLE CAM

PIVOTING HOOP CLAMP

MULTI FUNCTION DRUM KEY

- Single Pedal Complete P-3000D
- Double Pedal Complete (right footed) P-3002D
- Double Pedal Conversion Kit (right footed) P-3001D
- Double Pedal Complete (left footed) P-3002DL

- Demon Chain (Shown in Longboard Set Up) P-3000C

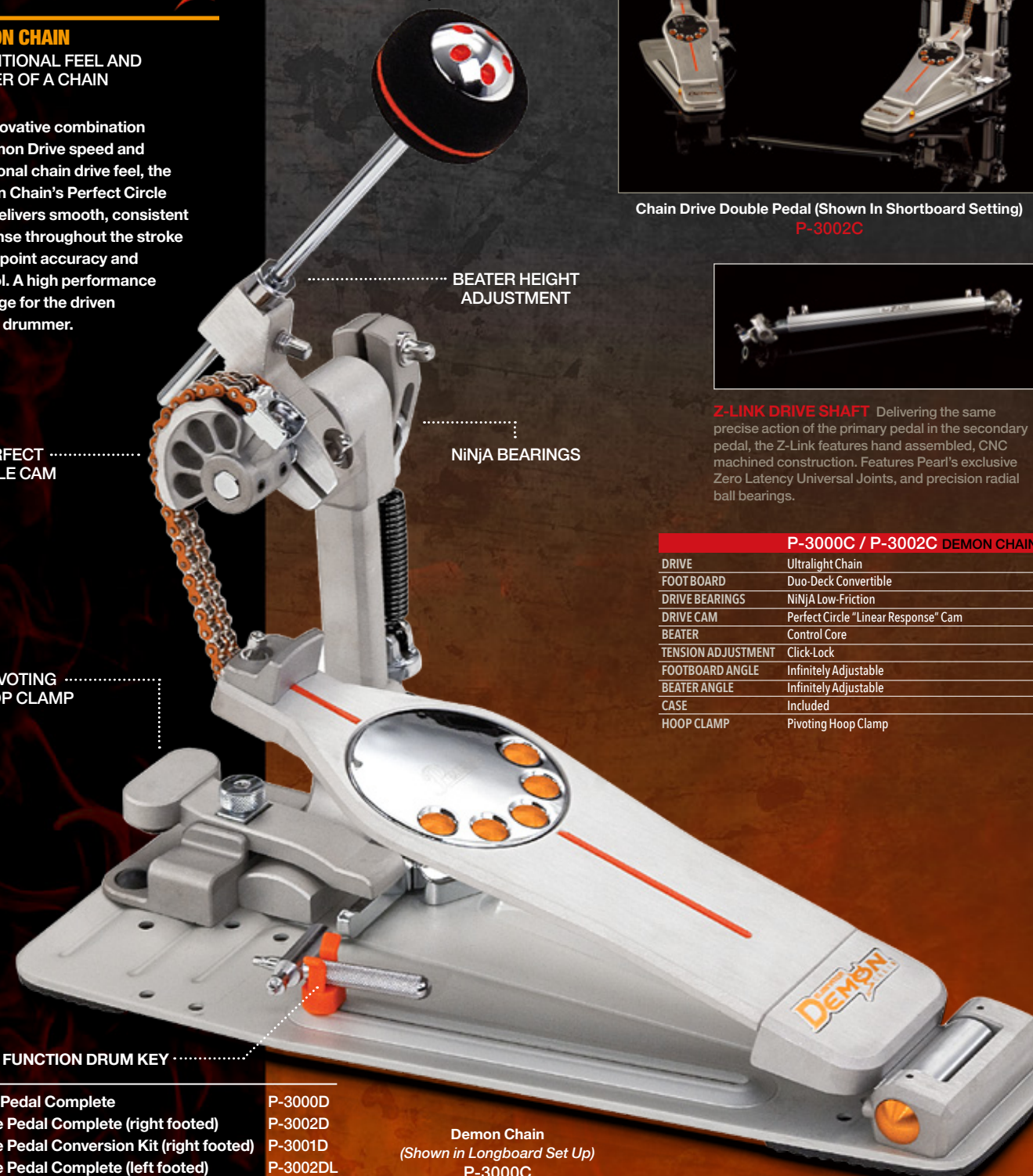

BEATER HEIGHT ADJUSTMENT

NiNJA BEARINGS

Chain Drive Double Pedal (Shown in Shortboard Setting) P-3002C



Z-LINK DRIVE SHAFT Delivering the same precise action of the primary pedal in the secondary pedal, the Z-Link features hand assembled, CNC machined construction. Features Pearl's exclusive Zero Latency Universal Joints, and precision radial ball bearings.

P-3000C / P-3002C DEMON CHAIN

DRIVE	Ultralight Chain
FOOTBOARD	Duo-Deck Convertible
DRIVE BEARINGS	NiNJA Low-Friction
DRIVE CAM	Perfect Circle "Linear Response" Cam
BEATER	Control Core
TENSION ADJUSTMENT	Click-Lock
FOOTBOARD ANGLE	Infinitely Adjustable
BEATER ANGLE	Infinitely Adjustable
CASE	Included
HOOP CLAMP	Pivoting Hoop Clamp

PERFECT CIRCLE CAM

Its racing inspired lines transfer energy from your foot into the head with minimal mass and maximum speed.



POWER CHAIN

This ultra lightweight, dual linkage Chain features low friction rollers for power and dependability.

ELIMINATOR : REDLINE

The Key to Ultimate Bass Drum Performance

ELIMINATOR REDLINE

CHOOSE A CAM REDLINE YOUR PERFORMANCE

The world's only pedal featuring the Patented Interchangeable Cam System, Eliminator: Redline's virtually unlimited tunability lets you lock in personally tuned feel, power, and speed. Like having four pedals in one, Redline pushes the boundaries of bass drum performance by fusing the power and flexibility of Pearl's original Eliminator with the fluid speed of our Demon series pedals.

CHAIN OR BELT DRIVE

*Shown w/ Optional Red Cam

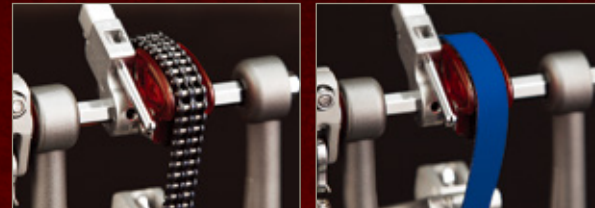

The sprocketless double chain drive on the Eliminator Redline (P-2050C) provides super smooth action with powerful and precise feel. The Eliminator Belt Drive model (P-2050B) provides a very comfortable, natural feel similar to a direct-drive system.

Eliminator: Redline
Single Pedal, Chain Drive
P-2050C

	P-2050C ELIMINATOR: REDLINE CHAIN	P-2052C ELIMINATOR: REDLINE DOUBLE PEDAL, CHAIN	P-2050B ELIMINATOR: REDLINE, BELT	P-2052B ELIMINATOR: REDLINE DOUBLE PEDAL, BELT
Drive	Sprocketless Double Chain	Sprocketless Double Chain	Steel-Reinforced Rubber Strap	Steel-Reinforced Rubber Strap
FOOT BOARD	Redline Reversible Traction Plate	Redline Reversible Traction Plate	Redline Reversible Traction Plate	Redline Reversible Traction Plate
DRIVE BEARINGS	NiNJA Low-Friction	NiNJA Low-Friction	NiNJA Low-Friction	NiNJA Low-Friction
DRIVE CAM	Interchangeable Cam	Interchangeable Cam	Interchangeable Cam	Interchangeable Cam
BEATER	Control Core Quadbeater	Control Core Quadbeater	Control Core Quadbeater	Control Core Quadbeater
TENSION ADJUSTMENT	Click-Lock	Click-Lock	Click-Lock	Click-Lock
BEATER ANGLE	Uni-Lock Beater Angle Cam	Uni-Lock Beater Angle Cam	Uni-Lock Beater Angle Cam	Uni-Lock Beater Angle Cam
POWERSHIFTER	Three Position	Three Position	Three Position	Three Position
CASE	Included	Included	Included	Included
HOOP CLAMP	Roller Cam Hoop Clamp	Roller Cam Hoop Clamp	Roller Cam Hoop Clamp	Roller Cam Hoop Clamp
UNIVERSAL JOINT	---	Length Adjustable, Latency-Free	---	Length Adjustable, Latency-Free

INTERCHANGEABLE CAM SYSTEM

Provides a choice of 6 different color-coded cams (4 included and 2 more optional). Quickly changes the power and feel of the pedal to suit your individual playing needs. Changing the cam is as simple as pushing the release button and snapping another in place.

Strong FEEL
Black
White
Blue
Purple (op)
Yellow (op)
Light Red

BEATER ACTION

BLACK CAMT-BK
Linear action cam

WHITE CAMT-WT
Oversized linear cam

BLUE CAMT-BL
Progressive cam

RED CAMT-RD
Radical progressive cam

PURPLE CAM-PL
Aggressive action cam
(Optional)

YELLOW CAM-YL
Inverse action cam
(Optional)



Eliminator: Redline
Double Pedal, Belt Drive
P-2052B

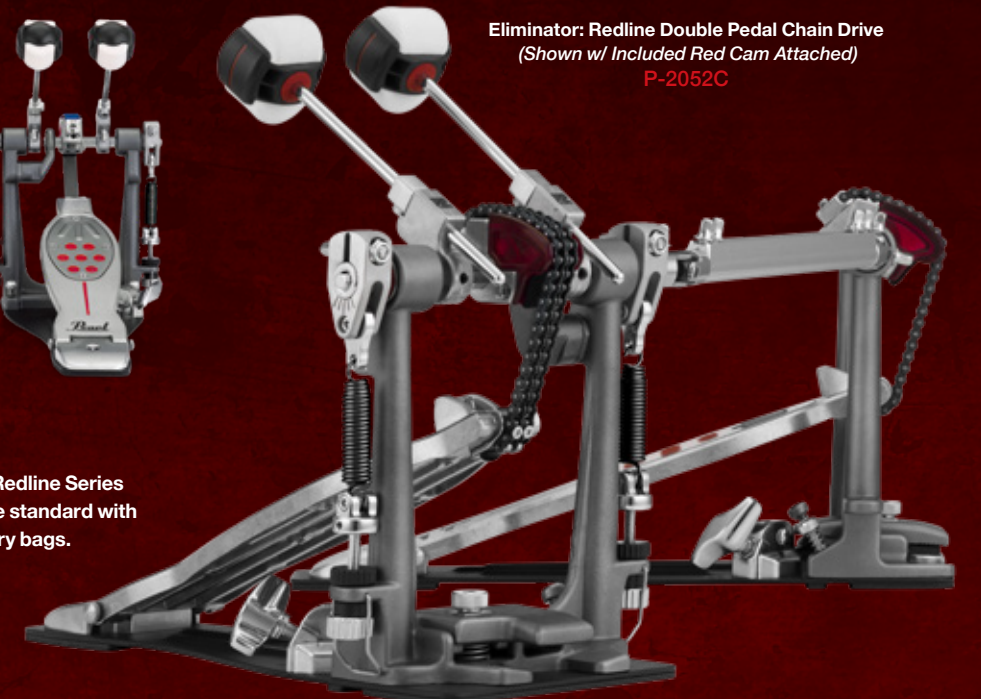

Eliminator: Redline Double Pedal Chain Drive
(Shown w/ Included Red Cam Attached)
P-2052C



Eliminator: Redline Series
pedals come standard with
Custom Carry bags.



POWERSHIFTER FUNCTION
By moving the foot board forward or back, our revolutionary PowerShifter function provides 3 positions to fine tune the power and feel of the pedal. Instantly change the drive angle leverage to create a light, regular, or strong feel.



NiNJA BEARINGS Developed by skateboarding engineers for the ultimate in fast, quiet performance, NiNJA Bearings incorporate state of the art micropolished steel balls for incredibly fast and smooth performance.



INDEPENDENT TRACTION GRIPS
Eliminator Redline's redesigned pedalboard features Pearl's exclusive reversible Traction Plate insert, allowing individual traction grip configuration to suit your exact playing requirements.



CLICK-LOCK SPRING ADJUSTMENT
w/ NEW Rotor Tension Cradle. Secures spring tension in high impact play. The counter spring adjustment's rolling cradle allows the spring to pivot with each stroke for less resistance. (U.S. Patent #7754953)



ZERO PLAY HINGE
Our proprietary stainless steel hinge provides maximum freedom of motion for blazing speed and prevents play between the footboard and heel. U.S. Patent #7179978



ROLLER CAM HOOP CLAMP
Mount Adjustment. Quickly adapts to a wide range of hoop thicknesses for the smoothest, most secure grip possible. Easy side access to the hoop clamp makes set up and tear down a breeze.

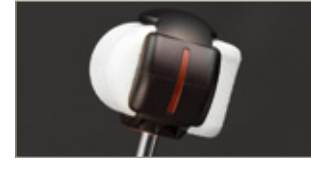

THE CONTROL CORE QUADBEATER
Provides four beater surfaces (two hard plastic, two felt) with the added feel of the vibration-free Control Core elastomer center. U.S. Patent #7626108



UNI-LOCK BEATER ANGLE CAM
Grips the axle a full 360 degrees, allowing infinite beater angle adjustments. Floating Spring Pendulum design is perfectly centered on the clamp for full bearing movement and maximum smoothness.

ELIMINATOR SOLO

ELIMINATOR SOLO : BLACK

Delivering blinding speed and powerful performance, Eliminator Solo bass drum pedals put the fleet footed player in control with all the gliding velocity that made Pearl pedals revolutionary. These no nonsense, streamlined Eliminator models deliver singular, resistance free feel for effortless play and driving performance.

The Solo: Black pedal's even, slightly weighted feel delivers just the right amount of resistance without slowing your stroke - for increased power and less muscle fatigue.

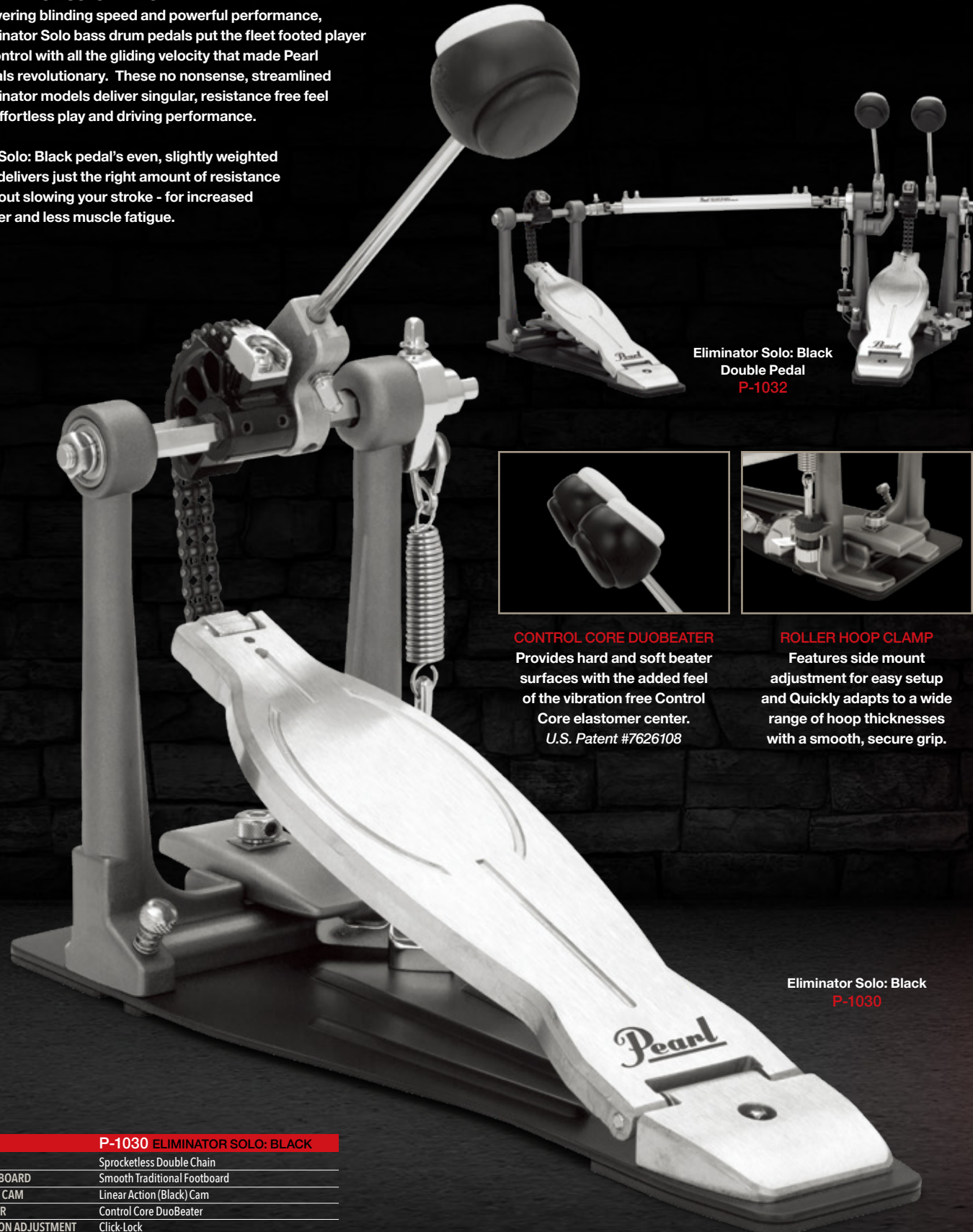

Eliminator Solo: Black Double Pedal P-1032

Eliminator Solo: Black P-1030



CONTROL CORE DUOBEATER
Provides hard and soft beater surfaces with the added feel of the vibration free Control Core elastomer center.
U.S. Patent #7626108

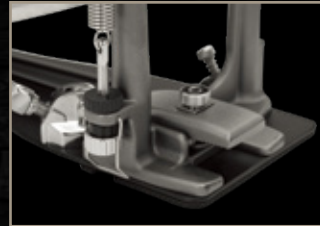

ROLLER HOOP CLAMP
Features side mount adjustment for easy setup and Quickly adapts to a wide range of hoop thicknesses with a smooth, secure grip.

Singular Feel, Eliminator Speed, Priced to Perform. Fly Solo and Set Your Feet Free!

ELIMINATOR SOLO : RED

Delivering accurate speed and focused performance, the Eliminator Solo: Red bass drum pedal delivers no-nonsense Eliminator feel for the technically decisive player.

Focusing the drive on the accurate feel of the Radical Progressive Action of Eliminator: Redline Red Cam, its shape allows the double chain to better match the motion of your foot. This means smooth movement at the bottom of the stroke with an accelerated PUSH at the top, and quick rebound for reactive doubles.

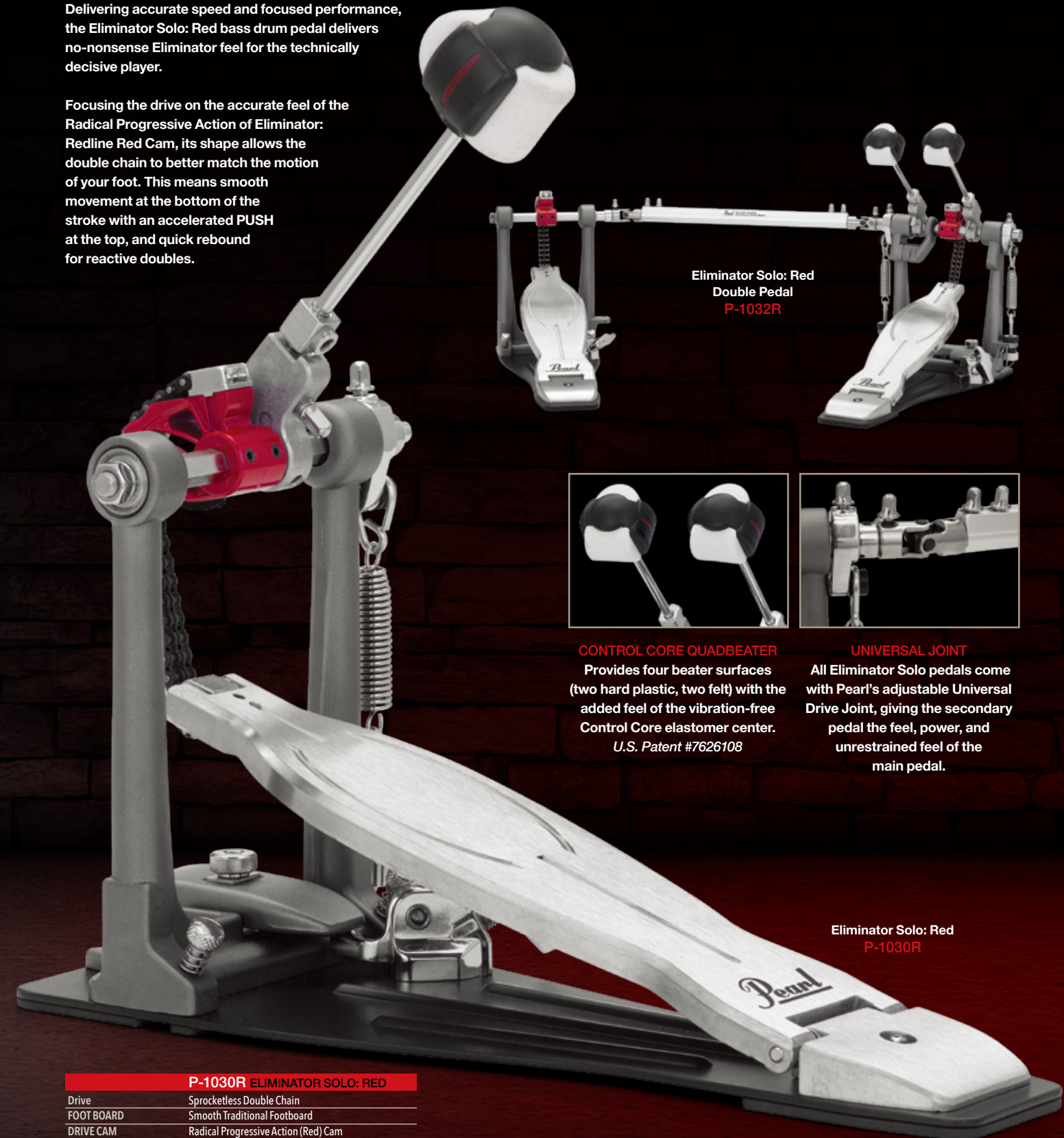

Eliminator Solo: Red Double Pedal P-1032R

Eliminator Solo: Red P-1030R



CONTROL CORE QUADBEATER
Provides four beater surfaces (two hard plastic, two felt) with the added feel of the vibration-free Control Core elastomer center.
U.S. Patent #7626108



UNIVERSAL JOINT
All Eliminator Solo pedals come with Pearl's adjustable Universal Drive Joint, giving the secondary pedal the feel, power, and unrestrained feel of the main pedal.

P-1030 ELIMINATOR SOLO: BLACK	
Drive	Sprocketless Double Chain
FOOT BOARD	Smooth Traditional Footboard
DRIVE CAM	Linear Action (Black) Cam
BEATER	Control Core DuoBeater
TENSION ADJUSTMENT	Click-Lock
BEATER ANGLE	Uni-Lock Beater Angle Cam
POWERSHIFTER	Three Position
HOOP CLAMP	Roller Cam Hoop Clamp

P-1030R ELIMINATOR SOLO: RED	
Drive	Sprocketless Double Chain
FOOT BOARD	Smooth Traditional Footboard
DRIVE CAM	Radical Progressive Action (Red) Cam
BEATER	Control Core Quad Beater
TENSION ADJUSTMENT	Click-Lock
BEATER ANGLE	Uni-Lock Beater Angle Cam
POWERSHIFTER	Three Position
HOOP CLAMP	Roller Cam Hoop Clamp

P930 / P932 PEDALS

Speed and Control for the Masses

SUPER SMOOTH, EXTREMELY FAST!

Merging quick rebound response of our flagship Demon Drive with the finely-tuned control of our award-winning Eliminator models, the P-930 bass drum pedal offers high end performance at a player accessible price. Its longboard playing deck delivers a lighter feel for increased speed, and offers advanced performance control and tunability with two rotor cam options. The ultimate pedal for fast feet on a budget.

P-930 BASS DRUM PEDAL	
Drive	Single Chain Drive
FOOT BOARD	Demon Style Long Board
DRIVE CAM	Perfect Circle Cam w/ Removable Eliminator Style Progressive Cam
BEATER	Control Core DuoBeater
TENSION ADJUSTMENT	Click-Lock
BEATER ANGLE	Infinite Beater Angle Adjustment
POWERSHIFTER	2 Position Powershifter Function
HOOP CLAMP	Adjustable Lever Clamp
UNIVERSAL JOINT	---

Single Pedal Complete	P-930
Double Pedal Complete (right footed)	P-932
Double Pedal Conversion Kit (right footed)	P-931
Double Pedal Complete (left footed)	P-932L



The P930 pedal is included as an upgrade in the 830 Series hardware pack and comes with Export drum sets.

Single Pedal Complete
P-930

2 POSITION
POWERSHIFTER
FUNCTION



Comes standard with Perfect Circle and removable Orange Progressive Cams, for fully tunable performance and increased control.

P-932 DOUBLE PEDAL COMPLETE

Double the speed, power and control with the P-932 Double Pedal.

Give your feet the gift of speed at a fraction of the cost of other "less innovative" pedals.

P-932 DOUBLE BASS DRUM PEDAL	
Drive	Single Chain Drive
FOOT BOARD	Demon Style Long Board
DRIVE CAM	Perfect Circle Cam w/ Removable Eliminator Style Progressive Cam
BEATER	Control Core DuoBeater
TENSION ADJUSTMENT	Click-Lock
BEATER ANGLE	Infinite Beater Angle Adjustment
POWERSHIFTER	2 Position Powershifter Function
HOOP CLAMP	Adjustable Lever Clamp
UNIVERSAL JOINT	Length and Position Adjustable



Double Pedal Complete
P-932



ORANGE PROGRESSIVE CAM
Can be removed to reveal the Perfect Circle for further tunability to match your playing style.



CLICK LOCK SPRING TENSION
maintains perfect tension gig after gig. Set it and forget it. (U.S. Patent #7754953)

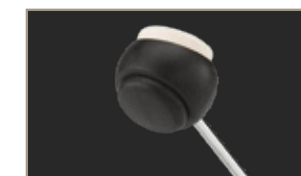

CONTROL CORE DUO BEATER
(U.S. Patent #7626108) utilizes an elastomer center to minimize vibration and features two unique playing surfaces (rounded felt and convex hard plastic surface) for quick-shifting tone and feel.



POWERSHIFTER FUNCTION
further tunes the power, feel, and leverage of the pedal by shifting the chain angle forward for lighter feel, or back for increased power.

P-920 / 922 DRUM PEDAL

Speed, Power, and Value

THE FAST TRACK TO BASS DRUMMING SPEED AND POWER

Fine-Tuned for a more refined playing experience, the P-920 bass drum pedal, featuring the patented Powershifter system (U.S. Patent #5574237), helps you modify your playing approach with an adjustable three position heel plate.

Locking the plate in forward, middle, or aft positions changes the chain drive angle and delivers light, standard, or strong feel with fast, accurate beater action.

P-920 BASS DRUM PEDAL

Drive	Sprocketless Double Chain
FOOT BOARD	Standard Length
DRIVE CAM	Round/Linear Action
BEATER	DuoBeat Two-Surface (Hard Plastic/Felt.)
BEATER ANGLE	Infinite Beater Angle Adjustment

P-922 DOUBLE BASS DRUM PEDAL

Drive	Sprocketless Double Chain
FOOT BOARD	Standard Length
DRIVE CAM	Round/Linear Action
BEATER	DuoBeat Two-Surface (Hard Plastic/Felt.)
BEATER ANGLE	Infinite Beater Angle Adjustment



POWERSHIFTER FUNCTION

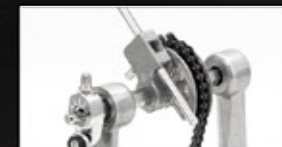

The Perfect Circle chain-drive cam



Single Pedal Complete
P-920



Double Pedal Complete
P-922

P-922 DOUBLE BASS DRUM PEDAL

The Powershifter double pedal offers the same individual playing feel from both pedals when attached to a single kick drum. Each pedal is individually adjustable with the adjoining universal joint accurately capturing every stroke with exceptional accuracy. Each two surface DuoBeater is easily switchable and angle adjustable for personalized action and quick response.

P-530 DRUM PEDAL

Play Faster, Right From the Starting Line.

P-530 DRUM PEDAL

With all the speed and function of a pro bass drum pedal at half the price, Pearl's P-530 Bass Drum Pedal features a dual chain and Linear Action cam drive for smooth, traditional pedal action and speed. The radius rod frame makes it highly portable for gigging, while features like a two surface DuoBeater and rotor tension axle clamp make it adaptable to virtually any feel or playing style.

P-530 BASS DRUM PEDAL

Drive	Sprocketless Double Chain
FOOT BOARD	Standard Length
DRIVE CAM	Round/Linear Action
BEATER	DuoBeat Two-Surface (Hard Plastic/Felt.)
TENSION ADJUSTMENT	Uni-Lock Beater Angle Cam

DUO BEATER

Made in the long-standing tradition of our professional-standard Double Bass Drum Pedals, the P-530 series features details like the two surface DuoBeater. Instantly transform your bass drum sound by choosing the quick attack of the Hard/Plastic side, or the more yielding tone of the Felt side.



LINEAR ACTION DOUBLE CHAIN DRIVE CAM

The look and feel of the P-530 series is inspired by Pearl's timeless Eliminator pedals. Its Linear Action Double Chain Drive Cams let you take every strike to the head with blinding precision.



EASY TRANSPORT

For easy set-up and tear-down, the P-530 series features a side-tensioned Hoop Clamp on the Radius Rod main pedal frame, and a Solid Baseplate on the auxiliary pedal, making it easily adaptable and fully transportable.



Single Pedal Complete
P-530

P-830 PEDALS

Light in weight but not in features, the P-830's Demon-style longboard increases playing surface for maximum leverage and speed. Its fully adjustable beater angle, Perfect Circle single chain cam, and DuoBeat two-surface beater deliver customizable feel for the player on the move.

P-830 BASS DRUM PEDAL

Drive	Single Chain
FOOT BOARD	Demon Style Longboard
DRIVE CAM	Perfect Circle
BEATER	DuoBeat Two-Surface
BEATER ANGLE	Infinite Beater Angle Adjustment



Single Pedal Complete
P-830

HI-HAT STANDS

Biggest Advancement In Time-Keeping Since The Wristwatch

H2050

Sharing many of the key characteristics of Pearl's Eliminator Redline bass drum pedals, 2050 Series Hi-Hat Stands deliver unparalleled versatility and customization in hi-hat pedal control. The world's-only hi-hat stand featuring the Interchangeable Cam System, 2050 Series stands' customizable options are designed to eliminate resistance, reduce fatigue, and increase performance.

"Night in and night out, Pearl hardware keeps everything right where it should be, and without fail!"
- OKWA ANDREWS

BRIAN FRASIER-MOORE
Pink

OKWA ANDREWS
Brian's Tech



CLA-130
Closed Hi-Hat
Bass Drum Hoop Mounted
Side-to-Side,
Forward/Back Adjustable
Ultragrip Wingnut
Spring Adjustable
Cymbal Spread



CLH-930
Closed Hi-Hat
Uni-Lock Tilter
Knurled Boom Arm
UltraGrip Wing Nuts
/Wing Bolts



CL-H70
Closed Hi-Hat
Multi-Angle Quickset Clamp
Gearless UniLock Tilter
Ultragrip Wingnut
Spring Adjustable Wash

Features Eliminator Solo traditional footboard, double braced swiveling tripod, and gigging weight tubing for touring professionals.

Features Eliminator Solo traditional footboard, single braced swiveling tripod, and reduced weight for gigging professionals.

Features an independent tripod positioned separately from the pedal frame, making it the only flat based hi-hat stand specifically for double pedals.

The RH2050 Remote Hi-Hat's low-friction cable produces smooth, lag-free performance with the lightning-fast action of the PosiLink Twin Cam drive system. Fast, natural-feeling cymbal play is finally accessible virtually anywhere on the kit, or to facilitate multiple hi-hat system setups.

Pearl's Rapid Lock Super Grip's slip-proof clutch system features a patented 360° lock nut that provides vice-like clamping force for a super grip.

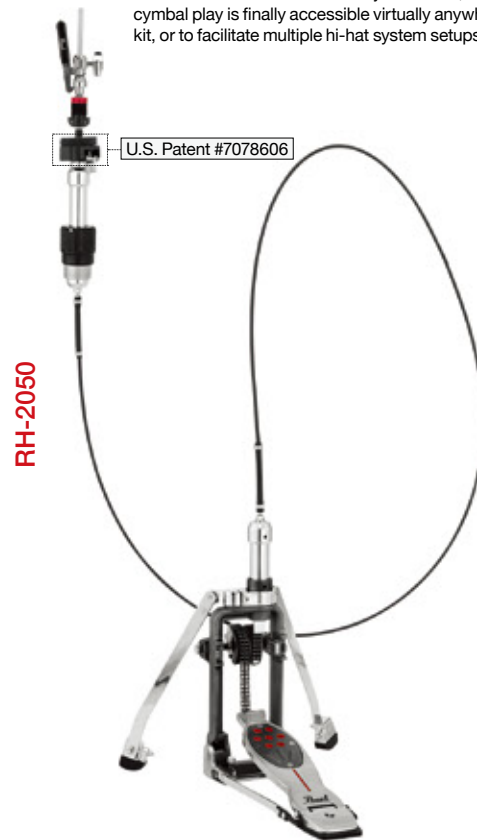

	RH-2050	H-2050	H-1050
Height Range	---	750 to 1030mm	700 - 960mm
Drive	PosiLink Twin Cam Drive System with Interchangeable Cams	PosiLink Twin Cam Drive System with Interchangeable Cams	Direct Pull Drive System
Footboard	Redline Reversible Traction Plate	Redline Reversible Traction Plate	Redline Reversible Traction Plate
Clutch	Rapid Lock Clutch (U.S. Patent #9355625)	Rapid Lock Clutch (U.S. Patent #9355625)	Rapid Lock Clutch (U.S. Patent #9355625)
Tension adjustment	Precision Spring Tension Dial	Precision Spring Tension Dial	Precision Spring Tension Dial
Leg Function	Swiveling Legs	Swiveling Legs	Swiveling Legs
Leg Tip	Spike/Rubber Tips	Spike/Rubber Tips (U.S. Patent #7371953)	Spike/Rubber Tips

	H-1030	H-1030S	H-930	H-830	H-150S
Height Range	760 - 940mm	760 - 940mm	760 - 940mm	610 - 910mm	745 - 865mm
Drive	Direct Pull Drive System	Direct Pull Drive System	Direct Pull Drive System	Direct Pull Drive System	Direct Pull Drive System
Footboard	Smooth Traditional Footboard	Smooth Traditional Footboard	Demon Style Long Board Footboard	Demon Style Long Board Footboard	Redline Reversible Traction Plate
Clutch	Standard Clutch	Standard Clutch	Standard Clutch	Standard Clutch	Standard Clutch
Tension adjustment	Precision Spring Tension Dial	Precision Spring Tension Dial	Precision Spring Tension Dial	---	Precision Spring Tension Dial
Leg Function	Swiveling Legs	Swiveling Legs	Swiveling Legs	Swiveling Legs	Swiveling Legs
Leg Tip	SureGrip Rubber Feet	---	SureGrip Rubber Feet	---	---



INDEPENDENT TRACTION GRIPS
Features Pearl's exclusive reversible Traction Plate and individual traction grips, configurable to suit your individual taste.



H-2050 PRECISION SPRING TENSION DIAL
Allows perfect tension control for fine-tuned response.



H-1050 PEDAL HEIGHT ADJUSTMENT
The infinite footboard angle adjustment featured on the H-2050 and H-1050 allows precise height matching in multi-pedal setups.



CLAMSHELL CLAMP
The H-2050, H-1050, H-1030, H-1030S, and H-930 Hi-Hat Stand uses beefy 1" tubing and clamshell clamps with built-in memory locks for superior rigidity.



HA-130
Positions your hi-hat next to your bass pedal in double bass set-ups for effortless transitions between pedals.



H-930 HI-HAT STAND
The H-930 Hi-Hat Stand features our Demon style longboard, double braced tripod w/ swivel function, and precision tension dial.



H-830 HI-HAT STAND
The H-830 Hi-Hat Stand is standard equipment with our Export series and offers a monochromatic Demon Style longboard design and swivel tripod.



H-150S* FLAT-BASED SWIVELING HI-HAT
The H-150S independent tripod is positioned separately from the pedal frame making it the only flat-based hi-hat stand with swiveling legs.

SNARE STANDS

No matter the gig or the drum, Pearl has a stand to accommodate both with security, high function, and chameleon-like diversity.

Every Snare Should Be So Lucky



S-1030



S-1030D



S-930

	S-1030	S-1030D	S-930
Height Range	480 - 700mm	310 - 520mm	470 - 670mm
Fit Snare	Adjustable Snare Basket: Fits Snare 10" - 16"	Adjustable Snare Basket: Fits Snare 10" - 16"	10" - 14"
Tilter	GyroLock Tilter: Infinite Angle Adjustability	GyroLock Tilter: Infinite Angle Adjustability	Uni-Lock Tilter
Arm Tips	Air Suspension Rubber Tips	Air Suspension Rubber Tips	Air Suspension Rubber Tips
Tripod	Trident Tripod	Trident Tripod	Double Braced Trident Style Tripod
Leg Tips	Oversize Super Grip Rubber Feet	Oversize Super Grip Rubber Feet	Sure Grip Rubber Feet



S-1030 SNARE STAND GYROLOCK
Our premier S-1030 model features Pearl's 360 degree infinitely adjustable GyroLock tilter for ease-of-use and pinpoint positioning.



S-1030 SNARE BASKET
The Pearl S-1030 Snare Stand adjusts to fit virtually any size snare from 10" to 16". The Air Suspension rubber tips securely cradle your prized snares while allowing them to fully resonate.



S-930D SNARE BASKET
The S-930D Snare Stand is a shorter version of the S930 Snare Stand, and is built to comfortably accommodate deeper snare drums.

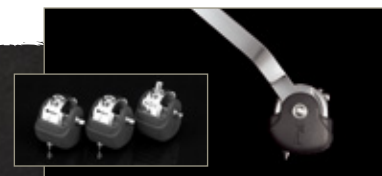

SPIKED / RUBBER FEET (Sold Separately)
Our CVT-300/3 Push Button Spiked/Rubber Feet come in pack of 3 to retrofit on any of our 1030 Series hardware for sure-footed performance on any terrain. (U.S. Patent #7371953)



S-930D

Drop basket for deeper snares



S-930S



S-830

Standard with Export Series drums, perfect for local gigging and easy transport

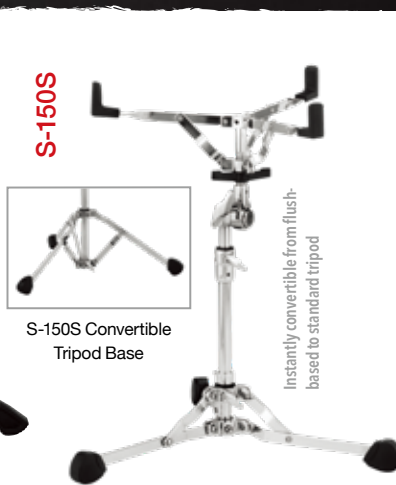

S-150S

S-150S Convertible Tripod Base

Instantly convertible from flush-based to standard tripod

	S-930D	S-930S	S-830	S-150S
Height Range	360 - 570mm	420 - 610mm	440 - 650mm	440 - 640mm
Fit Snare	10" - 14"	10" - 14"	13" - 14"	12" - 14"
Tilter	Uni-Lock Tilter	Uni-Lock Tilter	Uni-Lock Tilter	Gearless Uni-Lock Basket Tilter
Arm Tips	Air Suspension Rubber Tips	Air Suspension Rubber Tips	Rubber Grip	Rubber basket grips
Tripod	Double Braced Trident Style Tripod	Single Braced Trident Style Tripod	Double Braced Tripod	Stable Flat-Based Tripod
Leg Tips	Sure Grip Rubber Feet	---	Sure Grip Rubber Feet	Convertible Rubber Feet

DRUM THRONES

Sound Ergonomics

MULTI-CORE FOAM TECHNOLOGY: Roadster thrones now feature multiple layers of varied density foam which combine for a better playing foundation and improved feel.



D-3500BR



D-3500



D-1500TGL



D-1500RGL

	D-3500BR	D-3500	D-1500TGL	D-1500RGL
Height Range	495-665mm	495-665mm	495-695mm	495-695mm
Seat	Saddle-Style, Multi-Core Foam Cushion	Saddle-Style, Multi-Core Foam Cushion	15" Trilateral Multi-Core Foam Cushion	Option of a Saddle or Round top feel
Legs	Double Braced Legs	Double Braced Legs	Lightweight Aluminum Struts	Lightweight Aluminum Struts
StopLock	Lock/Spin System: Reversible StopLock allows cushion to be secured in place or free spinning depending on preference	Lock/Spin Reversible StopLock System	Gas Lift	Gas Lift
Notes	Detachable Backrest Mounts via Single Knob	Accepts Optional Backrest	Accepts Optional Backrest	Accepts Optional Backrest



D-1500SP



D-1500



D-1500S



DTBR-1535

	D-1500SP	D-1500	D-1500S	DTBR-1535
Height Range	525 - 630mm	495 - 665mm	445 - 615mm	12.5" x 7" Optional Backrest
Seat	15" Vented Round Seat	15" Vented Round Seat	15" Vented Round Seat	Formfitting and Breathable Removable Dual Axis Adjustability
Legs	Multi-Core Foam Donut Cushion	Multi-Core Foam Donut Cushion	Multi-Core Foam Donut Cushion	
StopLock	Double Braced Legs	Double Braced Legs	Double Braced Legs	
Notes	Lock/Spin Reversible StopLock System	Lock/Spin Reversible StopLock System	Lock/Spin Reversible StopLock System	
	Accepts Optional Backrest	Accepts Optional Backrest	Accepts Optional Backrest	
	Built-In Shock Absorber Post w/ Adjustable Spring Tension			



D-930



D-790



D-730S



D-50

	D-930	D-790	D-730S	D-50
Height Range	470 - 660mm	430 - 650mm	405 - 605mm	495 - 620mm
Seat	Round Vinyl Cushion	Round Vinyl Cushion	Round Vinyl Cushion	Round Vinyl Cushion
Legs	Double Braced Legs	Double Braced Legs	Single Braced Tripod	Double Braced Tripod

CYMBAL STANDS

Welcome to Boom Town

FOR EVERY CYMBAL, THERE IS A PLACE.

Advancing Drum Hardware for Serious Working Drummers since 1946. Through constant setup, teardown, performance, practice, and transport, Pearl has you covered with cymbal stand solutions that are ready to endure constant abuse and keep going.

Pearl hardware is literally the only hardware that you'll ever have to buy and it's all backed by their incredible lifetime warranty!

- TRACY BROUSSARD -

The most technically advanced boom stand ever devised. Perfect for studio or live applications.



	BC-2030	B-1030C	B-1030	BC-930
Type	Boom	Curved Boom	Boom	Boom/Straight
Height Range	800 - 2150mm	820 - 1900mm	820 - 1900mm	830 - 1800mm
Nut	WingLoc	WingLoc	WingLoc	Plastic Wingnut
Washer	Reversible Form / Felt Washer	Reversible Form / Felt Washer	Reversible Form / Felt Washer	Felt Washer
Cymbal Cup	Reversible Cup Washer w/ O-ring	Reversible Cup Washer w/ O-ring	Reversible Cup Washer w/ O-ring	Plastic Cymbal Cup
Tilter	GyroLock Tilter	GyroLock Tilter	GyroLock Tilter	Uni-Lock Tilter / Convertible Boom Tilter
Pipe Joint	Clamshell Clamp	Clamshell Clamp	Clamshell Clamp	Clamshell Clamp
Legs(Tripod)	Trident Tripod / Double Braced Legs	Trident Tripod / Double Braced Legs	Trident Tripod / Double Braced Legs	Trident Style Tripod / Double Braced Leg
Pipe diameter of stand	28.6/22.2/15.9mm	28.6/22.2/15.9mm	28.6/22.2/15.9mm	28.6/22.2/15.9mm

Reduced weight for easy gigging transport.

Offers lighter weight with advanced appointment designs.

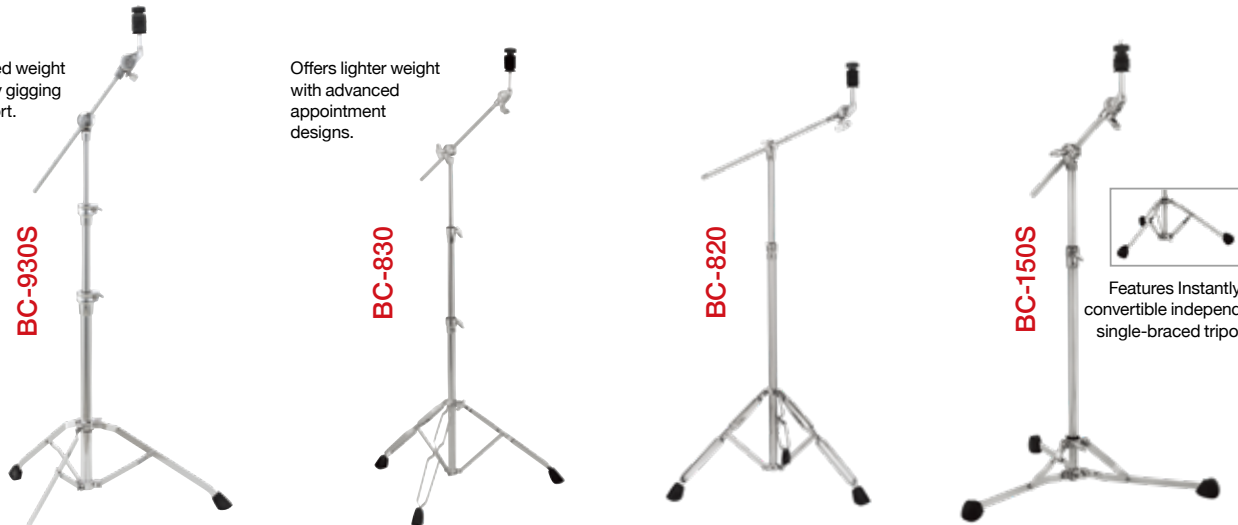

	BC-930S	BC-830	BC-820	BC-150S
Type	Boom/Straight	Boom/Straight	Boom/Straight	Boom/Straight
Height Range	780 - 1800mm	780 - 1480mm	900 - 1740mm	780 - 1300mm
Nut	Plastic Wingnut	Plastic Wingnut	Plastic Wingnut	Plastic Wingnut
Washer	Felt Washer	Felt Washer	Felt Washer	Reversible Felt/Foam Washer
Cymbal Cup	Plastic Cymbal Cup	Plastic Cymbal Cup	Plastic Cymbal Cup	Plastic Cymbal Cup
Tilter	Uni-Lock Tilter / Convertible Boom Tilter	Uni-Lock Tilter / Convertible Boom Tilter	Uni-Lock Tilter / Convertible Boom Tilter	Uni-Lock Tilter / Convertible Boom Tilter
Pipe Joint	Clamshell Clamp	Nylon Bushing Joint	Nylon Bushing Joint	Nylon Bushing Joint
Legs(Tripod)	Trident Style Single Braced Legs	Double Braced Legs	Double Braced Legs	Single Braced Tripod
Pipe diameter of stand	28.6/22.2/15.9mm	25.4/22.2/15.9mm	22.2mm/15.9mm	19.1 / 15.9 mm

Solid. Stable. Professional.

Exceptional stability for gigging and touring.

Built for rigid support and light transport.

Offers lighter weight with advanced appointment designs.

Features instantly convertible independent single-braced tripod.



	C-1030	C-930	C-930S	C-830	C-150S
Type	Straight	Straight	Straight	Straight	Straight
Height Range	770 - 1530mm	760 - 1500mm	780 - 1480mm	720 - 1480mm	670 - 1350mm
Nut	WingLoc	Plastic Wingnut	Plastic Wingnut	Plastic Wingnut	Plastic Wingnut
Washer	Reversible Form / Felt Washer	Felt Washer	Felt Washer	Felt Washer	Reversible Felt/Foam Washer
Cymbal Cup	Reversible Cup Washer w/ O-ring	Plastic Cymbal Cup	Plastic Cymbal Cup	Plastic Cymbal Cup	Plastic Cymbal Cup
Tilter	GyroLock Tilter	Uni-Lock Tilter	Uni-Lock Tilter	Uni-Lock Tilter	Uni-Lock Tilter
Pipe Joint	Clamshell Clamp	Clamshell Clamp	Clamshell Clamp	Nylon Bushing Joint	Nylon Bushing Joint
Legs(Tripod)	Trident Tripod / Double Braced Legs	Trident Style Tripod	Trident Style Tripod	Double Braced Legs	Single Braced Tripod
Pipe diameter of stand	28.6/22.2/15.9mm	28.6/22.2/15.9mm	28.6/22.2/15.9mm	25.4/22.2/15.9mm	19.1 / 15.9 / 12.7mm



Boomerang Curved Boom Arm with Clamp and Tilter
CHC-200



Boomerang Curved Cymbal Boom Arm
CHC-100



Boom Arm Cymbal Holder
CH-70



Mic Holder
MH-70A



Two Way Arm Clamp
DCA-180



Arm & Leg Cymbal Adapter (shown w/ DC-180)
CHA-70

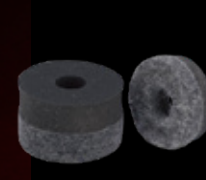

REVERSIBLE FELT / FOAM CYMBAL WASHERS allow four-way control of cymbal "ring" by mixing and matching the "hard" and "soft" surfaces of the washers.

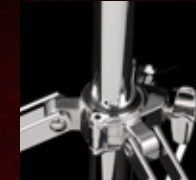

THE TRIDENT TRIPOD uses a full 360° of clamping force via the hinged collar. The inner tube rests in a nylon bushing to prevent metal to metal contact. Heavy duty legs feature lateral bracing for superior ultra quiet rigidity.



REVERSIBLE CUP WASHER w/ O-RING Specially designed to "float" normally or "lock" to prevent noise during recording.



WINGLOC

Quick Release Wing Nut Secure, adjustable, spring loaded cymbal nuts for quick set up and tear down.



NODAL POINT MARKINGS Pearl's BC-2030 features markings on the telescopic tubes that allow cymbals to achieve better clarity and sustain when the tubes are positioned at their respective Nodal Points. (U.S. Patent #9070348)



GYROLOCK TILTERS are infinitely adjustable and provide 360 degree range of motion for precise positioning with one-step convenience.

ICON RACK SYSTEM

The Original Drum Rack, Expanded



RACKS Preconfigured single and three-sided rack packages with rotating support feet.



MASTERWORKS SERIES STUDIO SHELL RECIPE
in Gloss Natural Artisan Sycamore with Ebony inlay & Black Nickel Hardware

MASTERWORKS SERIES with ICON RACK & e/MERGE
in Black Sparkle Burst to Granite Sparkle & Black Nickel Hardware



3-Sided Rack
(*also available DR-008 Expansion Bar)
DR-80

Developed in 1983 with legendary Toto drummer Jeff Porcaro, Pearl's original DR-1 Drum Rack was the first freestanding, frame based drum support system available.

Now, Pearl expands the **ICON** (short for Independent **CON**trol) Rack system with a fresh selection of upgrades and high function mounting options.

DR-80	
SUMMARY	3-Sided Rack
RAILS	Black Painted Steel 38.1mm x 910mm
PIPES	Black Painted Steel 38.1mm x 705mm
RAIL CLAMPS	PC-8 (x4)



Three-Sided Drum Rack, Straight
(w/ PCX-100X4 & PCL-100X2)
DR-513

DR-513	
SUMMARY	Three-Sided Drum Rack, Straight
RAILS	Aluminum, 40mm Square
PIPES	Steel 38.1mm x 865mm
RAIL CLAMPS	PCX-100 (x4)
PIPE CLAMPS	PCL-100 (x2)
SUPPORT FOOT	38.1mm x 475mm (P38475TA x4)
USABLE RAIL AREA	915mm (965mm From Center of Right to Left Clamp)



Three-Sided Drum Rack, Curved
(w/ PCX-100X4 & PCL-100X2)
D-R513C

DR-513C	
SUMMARY	Three-Sided Drum Rack, Curved
RAILS	Aluminum, 40mm Square
PIPES	Steel 38.1mm x 865mm
RAIL CLAMPS	PCX-100 (x4)
PIPE CLAMPS	PCL-100 (x2)
SUPPORT FOOT	38.1mm x 475mm (P38475TA x4)
USABLE RAIL AREA	1118mm (1168mm From Center of Right to Left Clamp)



Single Drum Rack, Straight
(w/ PCX100X2 & PCL100X2)
DR-511

DR-511	
SUMMARY	Single Drum Rack, Straight
RAILS	Anodized Aluminum Square Bar 40mm x 915mm
PIPES	Steel 38.1mm x 865mm
RAIL CLAMPS	PCX-100 (x2)
PIPE CLAMPS	PCL-100 (x2)
SUPPORT FOOT	38.1mm x 475mm (P38475TA x2)
USABLE RAIL AREA	915mm (965mm From Center of Right to Left Clamp)



Single Drum Rack, Curved
(w/ PCX100X2 & PCL100X2)
DR-511C

DR-511C	
SUMMARY	Single Drum Rack, Curved
RAILS	Anodized Aluminum Square Bar 40mm x 1118mm
PIPES	Steel 38.1mm x 865mm
RAIL CLAMPS	PCX1-00 (x2)
PIPE CLAMPS	PCL-100 (x2)
SUPPORT FOOT	38.1mm x 475mm (P38475TA x2)
USABLE RAIL AREA	1118mm (1168mm From Center of Right to Left Clamp)



Straight Drum Rack Expansion Bar w/ Support Leg
DR-511E

DR-511E	
SUMMARY	Straight Drum Rack Expansion Bar w/ Support Leg
RAILS	Anodized Aluminum Square Bar 40mm x 915mm
PIPES	Steel 38.1mm x 865mm
SUPPORT FOOT	38.1mm x 475mm (P38475TA x1)
USABLE RAIL AREA	915mm (965mm From Center of Right to Left Clamp)



Curved Drum Rack Expansion Bar w/ Support Leg
DR-511CE

DR-511CE	
SUMMARY	Curved Drum Rack Expansion Bar w/ Support Leg
RAILS	Anodized Aluminum Square Bar 40mm x 915mm
PIPES	Steel 38.1mm x 865mm
SUPPORT FOOT	38.1mm x 475mm (P38475TA x1)
USABLE RAIL AREA	1118mm (1168mm From Center of Right to Left Clamp)



Drum Rack Moveable w/Support T-Leg
DR-110T

DR-110T	
SUMMARY	Drum Rack Moveable Support T-Leg
RAILS	---
PIPES	---
SUPPORT FOOT	965mm x 64mm Round Chrome w/ P38475TA x1
USABLE RAIL AREA	---

RACK ACCESSORIES

An Industry Icon - The Professional's Choice

ICON RACK RECIPES

Check out Pearl's ICON Rack Recipe videos at www.youtube.com/@PearlDrumsUS for step-by-step instructions on how to get the most from existing and available Pearl Rack parts.

MOUNTING CLAMPS

Developed for the slip resistant ICON square rack rail and round support pipe. Each dramatically increases the level of setup flexibility and function variety.



Expandable Pipe Clamp
Fits All Icon Rack Leg Posts
PCL-100

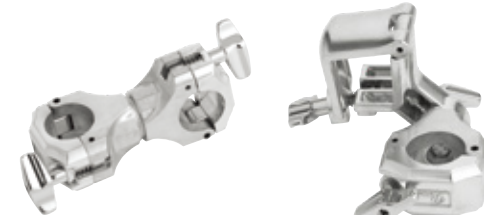

Dual Pipe Clamp
PCR-100

Pipe To Rail Clamp
PCR-200



Pipe To Rail Clamp
PCR-200L



Rotating Pipe Accessory Clamp
PCR-50X



Pipe Accessory Clamp
PCR-50L



Rotating Dual Pipe Clamp
PCR-50R



Curved Rack Rail Short w/ Clamp
AL-86AC



Curved Rack Rail Medium w/ End Caps
AL-103A



Icon Support Foot w/ TLJ-200 T-Clamp
P-38475TA



Icon Rail Accessory Clamp w/ Adjustable Jaw
PCX-100



Icon Rotating Pipe Clamp w/ Adjustable Jaw
PCX-200



Extended Rotating Rail Accessory Clamp
PCX-300



Pipe Clamp
Fits 7/8" tubes, for DR80
PC-8



Icon 6" Mini-Expansion Bar
RJ-50



Pipe Joint
RJ-100



ADP-20
2 Clamps
Fits 5/8" to 1-1/8"

AX-25
2 Revolving Clamps
Fits 1/2" to 1-1/8"

AX-25L
2 Revolving Clamps
Fits 1/2" to 1-1/8"

AX-28
In-Line & Revolving Clamps
Fits 5/8" to 1-1/8" & 1/2" to 1-1/4"

ADP-30
3 Adjustable Clamps
Fits 3/8" to 1-1/4"

TOM STANDS / ARMS

Positioning Possibilities Never Before Attainable



T-1035

T-1035L

T-935

T-835

TC-1035B

TC-1035BL

TC-935



CHB-75CA

CHB-75LB

CH-1030B

CH-930

CH-830

Mic Holder
MH-830

CH-1030BS

CH-930S

CH-830S



TH-1030

TH-1030S

TH-1030I

THL-1030

THL-1030S

TH-900S

TH-900I

TH-88S

TH-88I

TH-70S

TH-70I



UX-80S UX-80

Features rotating infinitely adjustable clamps for multiple uses.

Tube Height Extender
TX-100

Accepts 7/8" dia. tubes. Ideal for extending snare stand height.

Tube Extender for 1" Pipe
TX-125

Accepts 1" dia. tubes. Ideal for extending travel conga stands.



Chrome Multi Bass Drum Legs
PM-BDL3/C

Multi-Bass Drum Legs allow any bass drum to be played horizontally. Height and tilt adjustable.

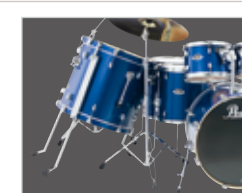

Bass Drum Mount Cymbal Holder
CHB-830

Mounts directly to the bass drum.

PEARL PERCUSSION ARTISTS

VIEW ALL THE PEARL ARTISTS AT:



AARON DRAPER John Mayer / Eminem / Adele
ALEKSANDRA SUKLAR Independent/Hans Zimmer
ALIOCHA ESCURIOLA Independent
ANDY FARAG Umphreys McGee
ARCHIE PENA Shakira
BART FERMIE Independent



BOBBY ALLENDE Tito Nieves
BRETT BAKER Rihanna / Jay-Z
BULU Drums United / independent
CHANGUITO Cuban Legend
COLIN DOUGLAS Aerosmith
CRYSTAL VARGAS Independent



DANIQUE KOS Independent
DOMINIQUE THOMAS John Legend / Jill Scott
EDDIE CONARD Independent
FIONA FOO Independent
GIANNA TAM Drums United/Independent
GIJS ANDERS VAN STRAALLEN Wouter Hamel / independent



HOLGER MUELLER Ernst Mosch und die Original Egerlaender/Independent
HORACIO HERNANDEZ Independent
JESSIE CARABALLO Marc Anthony
JESUS DIAZ Independent
LEA MULLEN Independent
MARC QUINONES The Doobie Brothers



MARCO TORO Drums United
MICHAEL ESCURIOLA Culcha Candela
NILS FISCHER Timbazo/CaboCubaJazz
OG Slightly Stoopid
PABLO ESCAYOLA Independent
PAPO PEPIN N.Y. Conga Legend



RAFA PEREIRA Janelle Monae
RHANI KRIJA Sarah Connor/Independent
ROLANDO MORALES MATOS The Lion King / Curtis Institute
SAMMY FIGUEROA Master Percussionist
TRILOK GURTU Independent
VALERIE DEE NARANJO The Lion King / Saturday Night Live

SIGNATURE SERIES

The Pros Play Pearl!

BOBBY ALLENDE

Bobby Allende is a mainstay in the New York Latin Music Scene and he demands the best from his drums, that's why he plays Pearl. His Signature drums are fiberglass with no seams to inhibit vibration which allow the drums to resonate freely for the full, rich sound that Bobby is famous for. The congas are 28 inches tall, fitting the traditional seated player perfectly while adding extra width to the base for added projection and stability. A matching set of bongos is also available.



#617 Confetti Signature Fiberglass Congas and Bongos



SHELL Seamless Fiberglass
HEADS Remo Fiberskyn3
RIMS Low-Rider Contour Crown
HARDWARE Brushed Steel
FINISH #617 Confetti
BONGOS PBF-300DXBA
OPTIONAL BAGS PSC-110CG 11" Quinto Conga Bag
 PSC-117CGW 11.75" Conga Bag
 PSC-125CG 12.5" Tumba Conga Bag

The Bobby Allende congas and bongos feature Remo Fiberskyn 3 heads for tuning stability and Pearl's Low-Rider crowns with a radical sloping edge that practically disappears under your hands for comfort you have to experience to believe.

If you demand excellence like Bobby, check out his Signature Fiberglass Congas and Bongos.

CONGAS
PCF-110DXBA 11" QUINTO
PCF-117DXBA 11.75" CONGA
PCF-125DXBA 12.5" TUMBA

BONGOS
PBF-300DXBA 7" & 8.5"

JESUS DIAZ

Cuban born Jesus Diaz is one of the most in demand percussionists and vocalists on the scene today. His active schedule provided the feature set for his signature series of congas and bongos. Designed for the seated player the Thai Oak drums measure 30" tall and from the Quinto to Tumba feature added girth to the belly of the drum. Seated conga players typically have to tilt the drum to achieve the desired projection, but the Jesus Diaz drums feature a 4" port on the front of the drum that is strategically positioned to deliver the maximum base frequency while the drum remains flat on the floor.

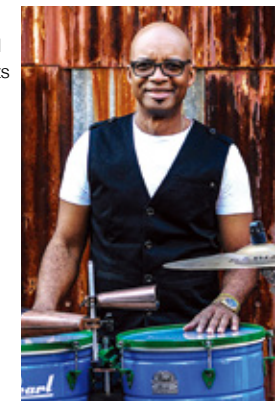

PHOTO: LISA KEATIN



SHELL Thai Oak
HEADS Buffalo Skin
RIMS Low-Rider Contour Crown
HARDWARE Quick Release Lugs
 Brushed Steel Finish
FINISH #580 Brushed Platinum
BONGOS PBW-300DXJD
OPTIONAL BAGS PSC-110CG 11" Quinto Conga Bag
 PSC-117CGW 11.75" Conga Bag
 PSC-125CG 12.5" Tumba Conga Bag

#580 Brushed Platinum Natural Buffalo Skin Heads

The drums also feature a newly designed Quick Release lug that is slotted to allow removal of the tension rod without fully removing the nut. Player comfort was also an important ingredient in the design of the hoop. A new ergonomically friendly design reduces the impact to your hands while an internal ring centers the natural buffalo skin heads for accurate placement.

CONGAS
PCW-110DXPJD 11" QUINTO
PCW-117DXPJD 11.75" CONGA
PCW-125DXPJD 12.5" TUMBA

BONGOS
PBW-300DXJD 7" & 8.5"

CONGAS & BONGOS

Tools of the Trade

ELITE SERIES

ELITE WOOD-FIBER CONGAS

PWFC-110DX - 11" QUINTO
PWFC-117DX - 11.75" CONGA
PWFC-125DX - 12.5" TUMBA

ELITE WOOD-FIBER BONGOS
PWFB-100DX - 7" & 8.5"

SHELL	Blended, Thai Oak over Fiberglass
HEADS	Natural Cow Skin
RIMS	Contour Crown
HARDWARE	Brushed Steel
FINISH	#648 Maduro Brown



ELITE OAK CONGAS

PCW-110DX - 11" QUINTO
PCW-117DX - 11.75" CONGA
PCW-125DX - 12.5" TUMBA

ELITE OAK BONGOS
PBW-300DX - 7" & 9"

SHELL	100% Thai Oak
HEADS	Premium Natural Cow Skin
RIMS	Contour Crown
HARDWARE	Brushed Steel
FINISH	#510 Caramel Brown



ELITE FIBERGLASS CONGAS

PCF-110DXA - 11" QUINTO
PCF-117DXA - 11.75" CONGA
PCF-125DXA - 12.5" TUMBA

ELITE OAK BONGOS
PBF-300DXA - 7" & 9"

SHELL	Fiberglass
HEADS	Premium Natural Cow Hide
RIMS	Contour Crown
HARDWARE	Brushed Steel
FINISH	#641 Blue Sparkle Burst



ELITE OAK CONGAS

PCW-110DX - 11" QUINTO
PCW-117DX - 11.75" CONGA
PCW-125DX - 12.5" TUMBA

ELITE OAK BONGOS
PBW-300DX - 7" & 9"

SHELL	100% Thai Oak
HEADS	Premium Natural Cow Skin
RIMS	Contour Crown
HARDWARE	Chrome
FINISH	#504 Mocha Burst



ELITE OAK CONGAS

PCW-110DX - 11" QUINTO
PCW-117DX - 11.75" CONGA
PCW-125DX - 12.5" TUMBA

ELITE OAK BONGOS
PBW-300DX - 7" & 9"

SHELL	100% Thai Oak
HEADS	Premium Natural Cow Skin
RIMS	Contour Crown
HARDWARE	Chrome
FINISH	#506 Merlot Burst



Also available in #532 Cherry Eucalyptus

ELITE OAK CONGAS

PCW-110DXG - 11" QUINTO
PCW-117DXG - 11.75" CONGA
PCW-125DXG - 12.5" TUMBA

ELITE OAK BONGOS
PBW-300DXG - 7" & 9"

SHELL	100% Thai Oak
HEADS	Premium Natural Cow Skin
RIMS	Contour Crown
HARDWARE	Gold
FINISH	#535 Satin Black



HAVANA SERIES

HAVANA CONGAS
PCF-110HV - 11" QUINTO

PCF-117HV - 11.75" CONGA

PCF-125HV - 12.5" TUMBA

HAVANA BONGOS
PBF-300HV - 7" & 8.5"



The wide belly shape of these high end, fiberglass drums produce deeper low tones and greater volume.

SHELL	Fiberglass
HEADS	Natural Cow Skin
RIMS	Contour Crown
HARDWARE	Chrome
FINISH	#644 Liquid Gold

SHELL	Fiberglass
HEADS	Natural Cow Skin
RIMS	Contour Crown
HARDWARE	Chrome
FINISH	#187 Silver White Swirl

SHELL	Fiberglass
HEADS	Natural Cow Skin
RIMS	Contour Crown
HARDWARE	Chrome
FINISH	#651 Red Tiger Stripe

PRIMERO PRO

PRIMERO PRO FIBERGLASS



11.75" & 12.5" Conga Set #628 Blue Marble
Shown with matching bongos
PFC-302DX



10" & 11" Conga Set
#621 Wine Red Marble
PFC-202DX



7" & 8.5" Bongos
#523 Carbon Vapor
PWB-100DX

11.75" & 12.5" Congas
#523 Carbon Vapor
PWC-302DX

PFC302DX626 #626 Gold Marble



Designed with professional features at an affordable price. Our expanded range of sizes offers 10" & 11" and 11.75" & 12.5" sets in both Thai Oak and Fiberglass with matching bongos.

PRIMERO PRO FIBERGLASS

PFC-302DX
 (11.75" & 12.5" Conga Set)
PFC-202DX
 (10" & 11" Conga set)

Offer added durability of fiberglass and are louder drums with a crisper sound than wood.

SHELL	Fiberglass
HEADS	Buffalo Skin
RIMS	Contour Crown
HARDWARE	Brushed Steel
FINISH	#621 Wine Red Marble #626 Gold Marble #628 Blue Marble

PRIMERO PRO OAK

PWC302DX
 (11.75" & 12.5" Conga Set)
PWC202DX
 (10" & 11" Conga set)

Primero Pro wood congas are made with Thai Oak and produce a warm, rich tone.

SHELL	Thai Oak
HEADS	Buffalo Skin
RIMS	Contour Crown
HARDWARE	Brushed Steel
FINISH	#511 Natural #521 Midnight Fade #523 Carbon Vapor

PRIMERO

Primero Series congas and bongos are available with fiberglass shells and in packages that include a double stand (PC-300W) or without stands.

SHELL	Fiberglass
HEADS	Buffalo Skin
RIMS	Contour Crown
HARDWARE	Black Powder Coat
FINISH	#602 Bistre Black

10" & 11" Conga Set w/ PC300W Stand
PFC-203



10" & 11" Conga Set
PFC-202

CONGA RESO-PLATE



Designed for the seated conga player, Pearl's Reso-Plate will give you that hard surface desired for maximum resonance. Configured with a cutout handle, the plates can also easily be placed on top of your drums for extra protection when packed in your conga case.

Conga Reso-Plates
PRP-140

TRAVEL



Congas, Bongos, & Timbales



Where can you take the Pearl Travel Congas and Bongos? The answer is anywhere you can take traditional drums but without any of the hassle. The Travel Congas feature a 3.5" deep wood shell with stave construction and Remo Symmetry heads. Available in three sizes: 11" x 3.5", 11.75" x 3.5" and 12.5" x 3.5" each with five precision Allen bolts. The 7" and 8.5" Travel Bongos feature 3.5" Thai Oak shells with Remo Fiberskyn heads and three point tuning. The Travel Congas and Bongos include a foam-handle tuning wrench.

CONGAS



11.75" Travel Conga
#510 Caramel Brown
PTC-1175N

12.5" Travel Conga
#510 Caramel Brown
PTC-1250N

11" Travel Conga
#510 Caramel Brown
PTC-1100N



Travel Conga Bag
PSC-1175TC



Travel Bongos Bag
PSC-785TB

The optional Travel Conga Stand works with all three size drums and features a tension lever mounting system that locks the drum into place. The wide based, double braced legs provide a solid foundation for your drum and prevents the stand from moving during performance.

BONGOS



Travel Bongos
#510 Caramel Brown
PTB-785



Travel Conga Stand w/ Carrying Bag
PC-800TC



Travel Bongos Stand
PC-800TB
PC-800TBS (Short)

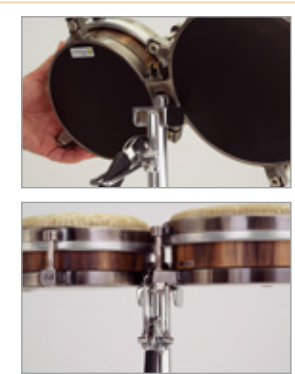

TIMBALES



Travel Timbales 14" & 15" with Stand*
PTTM-1415

*Bag sold separately



The Pearl Travel Timbales feature 14" and 15" steel shells that are professional size in diameter but only 4" deep.



The drums are connected by a hinge that marries them to the Quick Release stand. The custom hinge allows the drums to be folded together into the size of one standard depth timbale for easy storage and transportation.



The Travel Timbales come with a single braced stand that includes an 11.25" adjustable accessory post with 6 positions that allow cowbells and blocks to be placed the perfect distance from the player.



The steel shells feature a black lacquer finish and USA Remo clear Ambassadors heads for a truly professional sounding instrument. A soft carrying case for the stand is also included (sold separately).

TIMBALES



MARC QUIÑONES
Doobie Brothers

MARC QUIÑONES SIGNATURE TIMBALES



Marc Quiñones Signature Timbales
14"x7" / 15"x7" Steel w/ PT900 Tilting Stand and PBL30 Clave Block (Cowbell Not Included)
ETE-1415MQ



Primero
13"x7" Steel Timbale w/ PPS36 Mount
PTE-1336



Flat Timbale w/ I.S.S.
13"x3" Steel
PTE-3131



Tilting Timbale Stand (Short)
Height Range 26.5" to 36.5"
PT-900WS



Primero Timbales
13"x6.5" / 14"x6.5" Steel w/ PT-900 Tilting Stand (Stands & Cowbell Included)
PTS-5134



Primero Pro Timbales
14"x7" / 15"x7" Steel w/ PT-900 Tilting Stand (Sticks Included, Cowbell Not Included)
PTE-1415DX

COWBELLS

Pearl and Grammy Award winning artist Horacio Hernández have developed the ultimate family of cowbells. The HH-4XH bell features a quick release system that allows the bell to lift easily off of its mount for hand held playing.

HORACIO HERNÁNDEZ
Latin Legend



HORACIO HERNÁNDEZ SIGNATURE COWBELLS



Marybell
HH-5

Hand-Held Campana Quick Release
HH-4XH

Isabell Mambo Bell
HH-4

Chabella
HH-3

Clabell
HH-2

Bella
HH-1

AGOGO & TRIBELLS



Tri-Bells
PTB-30

Hand-Held Agogo
ECB-22

Mounted Agogo
ECB-23

NEW YORKER BELLS



Cha-Cha (High)
BCM-3NY

Cha-Cha (Low)
BCM-5NY

Mambo
BCM-7NY

Marc Quiñones Sig. Timbale Bell
BCM-8NYQ

BALA BELLS



Mounted Campana Bell
BCM-10

Hand-Held Campana Bell
BCH-10

AGOGO & TRIBELLS



Tri Agogo
PTA-30

Pro Cowbell Beater
PDC-60

Dual Cowbell Beater
PDC-10

PRIMERO COWBELLS



10" Bell w/ PPS30
PCB-1030

6" Bell
PCB-6

4" Bell
PCB-4

8" Guiro Cowbell
PCB-10GR

10" Millennium Chrome Bell
PCB-10MCR

10" Anarchy Bell
PCB-20

DJEMBES

Ancient Instruments for the Modern Percussionist

TOP TUNED DJEMBES

PBJV-8	8" x 16"	PBJV-12	12" x 24"
PBJV-10	10" x 19.5"	PBJV-14	14" x 25.75"



#685 Artisan Straight Grain Limba #686 Artisan Weathered Oak



#696 Purple Haze #697 Tribal Fire

ROPE TUNED DJEMBES

PBJVR-7	7" x 12.5"	PBJVR-12	12" x 24"
PBJVR-10	10" x 19.5"	PBJVR-14	14" x 25.75"



#684 Artisan Cypress #685 Artisan Straight Grain Limba



#698 Zebra Grass #699 Molten Scarlet

DJEMBES are a traditional African instrument that offer a wide variety of sounds and are perfect for drum circles.



Mahogany Djembe 12" Hand Carved #695 Malinke Village **PBJWR-12**
Field Percussion Djembe 14" (Fiberglass) #649 Textured Black **PJF350-FP**
Elite Oak Djembe 12.5" #511 Natural **PJW-340**
Elite Fiberglass Djembe #602 Bistre Black **PJF-350** 14" **PJF-320** 12.5"
Fiberglass Fun Drum **PFD-300**
Djembe Stand - Fits 8" to 14" Pearl Rope Tuned and Top Tuned Djembes **PBJ-STD**

DJEM-BASS



PJBs-350
Djem-Bass

The **PJBs-350** Djem-Bass Attachment allows you to convert any Pearl 14" djembe into a sub-sonic bass drum. To reduce the attack and add greater "lows," we have included a cloth cap that stretches around the head. For smoother low-end with a slightly reduced attack, slip the included neoprene disc inside, allowing for two distinct sound options. A pedal (not included) attaches via an I.S.S. clamp to the djembe's stand mounting plate. Includes two legs with mounting hardware, pedal bracket, head cover and neoprene muffler.

FOLKLORIC

FOLKLORIC ELITE CONGAS

Pearl's Folkloric line of congas feature a traditional look with modern innovation that only Pearl can deliver. Each 28" tall Oak drum is designed for the "seated" player, but includes stand mounts for players who prefer to stand. Thicker South American-style natural skin heads make the drums warm-sounding, but a fiberglass gel coating on the interior seals the shell and add the projection and volume desired by today's players. Four Polished Steel Reinforcing Bands are inset on the shell for a smooth touch, and the traditional hoops complete these stunning Cuban instruments.



Folkloric Elite Bongos 7" & 8.5" **PBW-300FC**
Tumbador 12.5" **PCW-125FC**
Quito 11" **PCW-110FC**
Segundo 11.75" **PCW-117FC**
 #526 CRIMSON SUNRISE



Uno **PSK-50FC**
Segundo **PSK-60FC**
Caja **PSK-70FC**
Fiberglass Shekere **PSK-10**
10" Segundo Shekere **PBSK-70**

BATS

Bata drums originated in Nigeria over 500 years ago and were primarily used for religious purposes. The drums were introduced into Cuba by slaves in the 1820's. Pearl Batas are modeled after an ancient Cuban design and feature naturally finished 100% Thai Oak shells for outstanding and authentic tone. Polished steel traditional rims offer excellent tuning integrity and ease of tuning. These prized ceremonial drums have an hourglass shape and produce a great, warm tone similar to a bongo-like sound on the high drum and a djembe-like tone on the large drum.



Itotele **PBA-60**
Oconcolo **PBA-50**
Iya **PBA-70**



Wood Clave **PCL-20FCW**
Bamboo Clave **PCL-10FCB**
Shekere Holder **PPS-45**
Guataca **PGT-10FC**
Cata w/ Holder **PCA-14FC**

BRAZILIAN

BRAZILIAN PERCUSSION

Modern refinements and Pearl quality to the traditional Samba musician.

The Timbao is made from lightweight fiberglass, and is capable of the extremely high tension utilized in tradition Brazilian ensembles. The lightweight wood shell Surdos allow for hours of comfortable play when worn over the shoulder with the provided strap. Available in 18"x22", 20"x18" and 22"x22" sizes (diameter x depth), Pearl's popular Surdos continue to be the industry standard.

Our Repinique features lightweight yet sturdy steel shells with etched heads, shoulder straps and low rims for incredible playing comfort.



Timbao **PBTB-140**
Tan Tan **PBTA-1420**
Surdo 20" **PBS-2018**
Surdo 18" (Shown with optional PBS30BD) **PBS-1822**
Surdo 22" **PBS-2222**
Legs & BD Adapter Kit For Surdo **PBS-30BD**



Tamborim Stick **PBT-70S**
PBSM-20 **Surdo Mallet**
PBCX-1204 **Caixa 12"x4"**
PBCX-1265 **Caixa 12"x6.5"**
PBC-80SS **Caixa**



Pandeiro 10" (5 Sets Platinillas & Goatskin Head) w/ Bag **PBP-510**
Pandeiro 12" (6 Sets Platinillas & Plastic Head) w/ Bag **PBP-612**
Pandanza w/ Agogo Bell **PDZ-510**
Tamborim w/ Quick Draw Mount **PBT-60C**

CAJONS

PRIMERO CAJON

The body of these Primero cajons is constructed using MDF, Medium-density Fiberboard which creates a solid and durable sound chamber. Four of these models feature Meranti faceplates. Meranti is a wood known for its relative hardness and straight grain making it ideal for cajons. A built in bass port magnifies the massive low-end tone of the cajon while two sets of fixed snare wires provide a bright, crisp snare response. Each of these Primero cajons feature a look as distinctive as the percussionist who play them.



PRIMERO ABSTRACT RED CAJON
PBC-120B

FACEPLATE Meranti*
BODY Medium-Density Fiberboard
SNARES Fixed, two sets
BASS PORT Patented, built in, rear facing

Its unique finish is an abstract red print on a cloth sarong that is applied to the body of the cajon and is accentuated by the ebony front.

Finish :
Abstract Red body with black faceplate
19.25" T x 11.75" W x 11.75" D



PRIMERO FIGURED CHERRY CAJON
PBC-121B

FACEPLATE Figured Cherry*
BODY Medium-Density Fiberboard
SNARES Fixed, two sets
BASS PORT Patented, built in, rear facing

Features a stunning figured Cherry faceplate. Because of its hardness, tonally cherry is a close match to maple and when used on a cajon provides more bottom-end.

Finish :
Natural Figured Cherry with gloss black body
19.25" T x 11.75" W x 11.75" D



CYCLONE CAJON
PCJ-629616

Simply twist open the Brazilian Platinnella-style jingles and a new world of sonic options open up, as you sound like two percussionists blending simultaneously.

#616 Artisan Wood Grain
18.75" T x 12.5" W x 12.5" D



BOOM BOX CAJON
PCJ-633BB

FACEPLATE Figured Cherry*
BODY Medium-Density Fiberboard
SNARES Fixed, two sets
BASS PORT Patented, built in, rear facing

#635 Artisan Zebra Wood
18.75" T x 12.5" W x 12.5" D

The Boom Box Cajon creates never-before heard low-end frequencies from a Fiberglass cajon! Features a fixed snare system and a built-in bass port for subsonic frequencies you have to hear to believe!

CAJON ACCESSORIES

Enhance your performance by adding dynamic new sounds. Jingle Cups can be added to the face of any Cajon or even to acoustic guitars and other drums. The Cajon Clave and Wood Blocks attach to your cajon using the provided 3M Dual-Lock Tape or can be played handheld or stand mounted. The Cajon seat cushion



CAJH-100
Cajon Holster Nylon
w/ Velcro Straps



PBCR-1535
3 Way Cajon Riser
First Lift = 21", Second Lift = 23",
Third Lift = Angled Option



PSC-BC
Box Cajon Seat Cushion
w/ Thick Foam. Adds comfort for long sessions.



PBCW-10
Wood Block
w/ Dual-Lock Tape & Mounting Bracket (PPS37 Not Included)



PBCC-100
Clave Block
w/ Dual-Lock Tape & Mounting Bracket (PPS37 Not Included)



PJCP-1/6
Jingle Cups
Two Pack Suction Cups Attach to the Cajon Face



PCAP-100
Agogo bell
This easy-to-attach accessory provides a sharp cutting sound to your cajon percussion rig.



PCAM-100
Agogo bell
Easily enlarge your sound Hook-and-loop fastener



PCC-100
Cajon Clapper
The Cajon Clacker is a new Pearl cajon accessory by Bart Fernie, combine "clak" sound with Box Cajon.



PCJ-70STD
Cajon Stand



PSC-BC1213
BASS CASE

The PSCBC1213 BassCase allows you to transport your prized cajon in protected style and then convert the case into an incredible sounding bass drum. The PSCBC1213 BassCase is constructed from heavy duty black nylon and has a mounted 13" drum head with internal muffling.



BRUSH BEAT CAJON
PCJ-633BT

Fiberglass construction enhances the projection of this unique cajon. The black portion features a textured surface that responds well to brushes and other effects. Fixed snares provide a crisp response through the rear facing bass port.

18.75" T x 12.5" W x 12.5" D



BOX CAJON CASE
PSJ1-213CJ

Sized to fit most box cajons Pearl's case features heavy-duty nylon construction, plush padded interiors, ergonomic carrying handles, durable double zippers, an external pouch and rubber feet at the ground-resting points.

13" T x 14" W x 20" D

Get in the Cajon Zone!

100° Ergonomic Playing Position



CENTIGRADE CAJON
PCJ-650CG

This Fiberglass cajon features a front faceplate with 100° of angle for less stress on your lower back. The molded rear bass port projects a full, rich bass tone.

#650 Mango Cherry Burst
19" T x 13" W x 13.25" D



SAMBAJON
PCJ-SBJ

This Fiberglass cajon has two playing surfaces: a traditional hardwood front faceplate and a padded, cloth covered side that produces a Brazilian Surdo / "808" style bass tone. Perfect for use with any cajon pedal.

Black Lacquer Finish
19" T x 12.75" W x 12.5" D



CYCLONE CAJON
PCJ-647CYC

The Cyclone Cajon is the latest in our diverse offerings of unique Peruvian instruments. Finished in a classy black lacquer and featuring stylish Burnt Orange racing stripes, this curved-back fiberglass cajon is as hip looking as it is sonically powerful.

Burnt Orange racing stripes
18.75" T x 12.5" W x 14" D



TWO-FACE CAJON
PBC-512TF

The New 2Face Cajon from Pearl Percussion has two distinct personalities. The professional quality wood construction box drum is ported on the side with two different playing faces on the front and back.

#512 Sheer Black



CUBE CAJON
PCCS-629

Pearl Percussion is proud to introduce the newest member to its family of cajons, the Cube Cajon! Small in stature, but large in sound.



WEDGE TRI-SIDE CAJON
PCJ-3000B

This unique pie slice shape offers a natural seated playing position and 2 striking surfaces. Fiberglass construction with fixed snares and Artisan II finish. Ported in rear.

18.5" T x 14" W x 14" D



BOOM BOX CAJON
PCJ-633BB

This Fiberglass cajon with fixed snares features a built in bass port that magnifies subsonic frequencies for great bass projection.

#633 Artisan Red Mahogany
18.75" T x 12.5" W x 12.75" D



PRIMERO BOX CAJON
PBC-507

Get started with Primero. Constructed from Asiatic Pine with fixed snares, this model has the right pitch and price.

#507 Gypsy
19.75" T x 12.5" W x 12.5" D



FUN BOX CAJON
PFB-300

Help your child develop proper playing mechanics while playing this smaller kidfriendly size cajon. Durable Fiberglass construction finished in bright yellow.

13.75" T x 9.5" W x 10" D

HANDPANS

A Cosmic Blend of Sound

MELODIC HANDPAN



22" Melodic Handpan
9 Note D Minor - Patina Finish
PBHP-500

Handpans are musical instruments that are a subset of the steelpan. The beautiful tonal characteristics will remind you of steel drums, but handpans are only played by hand, with no sticks or mallets, so the sound has reduced attack but is much more mellow.

The shape of Pearl's 22" Awakening Series Melodic and Euphonic handpans feature a center tone field surrounded by eight tone fields. Each

tone field has a fundamental note, an octave, and an overtone, so each field has three notes. The hand-crafted steel construction of the instrument is designed so each tone field holds its tuning.

The Melodic handpan features a patina finish and is meticulously tuned to the D Minor scale, and responds to your finger strikes with excellent sonority.

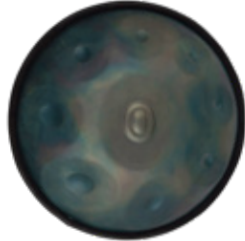
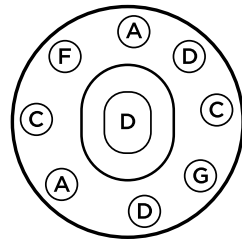

Hand Hammered Tone Field



Rubber Edge Protection



Padded Case Included

HANDPAN ACCESSORIES



PTTD-10

8" x 1.75" Donut
Foam Wrapped PVC



Adjusts from 36"-40" tall

Handpan Floor Stand
PBFS-30



Fits any 20"-22" handpan

Handpan Case
PBHPB-50

TONGUE DRUMS

Engineered for the Professional Percussionist



AWAKENING SERIES TONGUE DRUMS

Pearl proudly introduces the Awakening Series of 6 Tongue Drums: Three 8 note and three 9 note drums tuned to pentatonic scales.

Tongue drums derive their name from the tongue shaped areas where you strike the drum. The results are a cosmic blend of tones that are as much fun to hear as play.



8 Note G Major #687 Blue Burst
PMTD8GMF



8 Note A Ake Bono #688 Brown Burst
PMTD8AKBF



8 Note A Minor #689 Green Burst
PMTD8AMF



9 Note C Lydian #690 Orange Burst
PMTD9LYDF



9 Note C Major #691 Crimson Burst
PMTD9CPTF



9 Note C Ake Bono #692 Purple Burst
PMTD9AKBF



9 Note C Ake Bono
#692 Purple Burst
PMTD9AKBF



Rubber mallets included

Each drum features a 10" hardened steel shell with precise laser cut tongues for accurate and consistent tuning. Pearl Tongue drums can be played with your fingers or with a set of mallets included with each drum.

TONGUE DRUM BAG



Tongue Drum Bag
PTDB-10B

AWAKENING SERIES

Rainsticks and Nut Shakers

RAINSTICKS

BAMBOO RAINSTICKS WITH BURNED FINISH #694 RHYTHM WATER



Pearl's natural Bamboo Rainsticks are 2.5" in diameter and feature an internal spiral maze of tines that a cascade of lava pebbles flow over to create the soothing sound of falling rain.

Pearl has expanded its line of shakers to include six Bamboo rainsticks ranging in size from 16" to 60" and available in two unique finishes.



BAMBOO RAINSTICKS WITH PAINTED FINISH #693 HIDDEN SPIRIT

NUT SHAKERS

The Awakening Series has been expanded to include a series of natural nut shakers that provide earthy tones that complement the series. Kenari, Bendo, and Pangli nuts range in size from small, medium, and large and each size

possesses unique sound properties. From the recording studio to the yoga studio Pearl's Awakening Series has an instrument and sound that will inspire you.



20 INDIVIDUALLY STRUNG PANGI NUTS
Deeper, earthy tone.

BAMBOO HANDLE
Gives player more control.

16 STRANDS OF BENDO NUTS
Bright, woody tone.

14 HAND STRUNG KENARI NUTS
Worn to layer sounds.

MAHOGANY CROSS BAR
Suspended nuts for unique earthy sounds.

22 STRANDS OF KENARI NUTS
Full, robust tone.

CONCERT PERCUSSION

Engineered for the Professional Percussionist



Pearl is proud to offer Concert Percussion instruments that are attractively priced for school ensembles, yet engineered with the professional percussionist in mind. The symphonic tambourine is a perfect example. Its 17 pairs of specially aged, stamped brass jingles provide a dry, yet bright tone that brings added color to any musical situation. Its 10" headed wood frame allows the

player to effortlessly perform all tambourine techniques, and the tambourine's plush carrying case is included. The rattler is another vital component to any concert percussionists' equipment, and Pearl's is built with an extended handle for a comfortable grip and ease of playing. Holders for the rattler and castanets are also available.



Mix Copper And Brass
PETM-1018CR

Mix Copper and Bronze
PETM-1018CB

Mix German Silver and Copper
PETM-1018GC

Beryllium Copper
PETM-1018CP

German Silver
PETM-1018GS

ORCHESTRAL TAMBOURINES

The Pearl Orchestral Series Professional Tambourines provide performers a new voice and sound for any performing situation. These 5 instruments feature uniquely sourced and hand-

hammered jingles combinations of German Silver, Phosphor Bronze, Beryllium Copper, and Yellow Brass that give a full spectrum of color and projection options to players. The 10" shell is a well-balanced and lightweight 2-ply Mahogany

design with contoured hand-hold areas for comfortable performance and warm tone. The natural finish goatskin head provides a full responsive sound and traditional look without sacrificing durability.



16" Ocean Drum
PSFM-16

14" Frame Drum
PFR-14C

Frame Drums Set of 6 - Sizes: 8", 10", 12", 14", 16", 18"
PFR-0818C



Castanets (Long Handle)
PCN-20

Castanets
PCN-20S

Castanets Holder
PCN-20H

Slap Stick
PSS100-

Elite Concert Wood Blocks (High)
PCWB-100A

(Medium)
PCWB-200A

(Low)
PCWB-300A

Mounting Bracket incl.

ELITE TRIANGLES



Stix-Free Triangle Holder w/ 8" Triangle
PPS-12T

Triangle
10" **PET-100**
8" **PET-80**
6" **PET-60**

Triangle Beater
PETB-30

Triangle Clip
PTC-10

Rattler Mounting Clamp
PRT-10C

Temple Blocks
PCWTB-05

Rattler
PET-100

HAND PERCUSSION

A World of Hand Percussion

BLOCKS, BELLS, SHAKERS and more. Choose from a complete selection of hand percussion instruments to add color and impact to your music.



Natural Gourd Guiro
PNG-20

Two scraping surfaces: thin grooves on one side for a lighter sound and thicker cut channels on the other side for a beefier sound. The interior is coated with a fiberglass get to add projection and volume.



Metal Guiro
PMG-20

Perfect for Merengue rhythms, or just a different metallic sound texture, Pearl's Metal Guiro will become an essential ingredient in your "toy" bag. Scraper included.



Fiberglass Guiro
PFG-20

Pearl's Fiber Guiro is light-weight and provides optimal projection due to its fiberglass construction. With the included striker and two different playing surfaces you have a world of sonic possibilities in your hand.



Guiro Holder
PGH-20

This innovative design will hold virtually any size guiro secure for one handed playing. Easily mountable off the lug of your conga or any 3/8" post, Pearl's Guiro Holder uses a track system to lock the guiro in place. Included is a 3/8" "Z" rod so you can also mount your favorite accessory as well.



Beaded Maracas
PFM-20

The Beaded Maracas feature Shekere-style beads which offer an excellent sound with greater control, and foam handles for enhanced comfort.



Maracabasa
PFM-50

The Maracabasa is two great instruments in one, combining the functionality of a maraca and a cabasa in one handheld instrument. Featuring a ribbed fiberglass body wrapped in shekere-style beads.



Basket Ganza 9" X 4"
PGA-20

The Pearl basket ganza is a 9"x4" woven tube containing wooden sticks instead of conventional shot. The wood sticks produce an airy percussion sound.



Shakelets
PWR-40

This innovative percussion item feature exclusive "Ganzinellas", Brazilian-style plantinellas combined with ganza shakers that are worn on the wrists to produce a shaker sound when playing.



Spirit Chimes w/
Holder and Mallet
PSC-30BR

Spirit Chimes have many applications in school bands, percussion ensembles and music programs. They are also perfect for meditation and yoga studios.



36 Anodized Aluminum Chimes
w/ Case, Holder, And Striker
PWCH-3620A

- Satin black frame with polished bars
- Self-dampening parallel swinging chimes



32 Bar Aluminum Windchimes
w/ Case, Holder, and Striker
PWCH-3220A

- 32 Anodized Aluminum Chimes
- Self-dampening parallel swinging chimes



Foldable 36 Anodized
Aluminum Chimes
PWCHF-3620AF

- Individually strung, goes from 19.25" to 9.75"
- Self-dampening parallel swinging chimes



Quickmount Tambourine
w/ Steel Jingles
PTM-10SHX

Six double rows of premium steel jingles deliver a bright metallic sound. Features a comfort grip handle that slides into the shock-absorbing Quickmount bracket. Mounts to any 3/8" post.



QUICKMOUNT BRACKET
Hand-held to
mounted in seconds.



Quickmount Tambourine
w/ Brass Jingles
PTM-10GHX

Six double rows of premium brass jingles deliver with bright and a warm metallic sound. Comfort grip handle that slides into the shock-absorbing Quickmount bracket. Mounts to any 3/8" post.



COMFORT GRIP HANDLE
Molded ergonomic shape.



PTM-50BHR (Brass)
Ultra Grip Volume
Adjustable Tambourine

The jingle control discs can be moved to the outside to allow the jingles to ring freely. As the jingle control discs are tightened the more restricted the jingle.

Brass is an alloy of copper and zinc and the jingles provide a bright mid-range tone. Steel jingles have a higher tone with extra top end and sustain.



PTM-50SHR (Stainless Steel)



9" Primero Rock Tambourine
w/ Millennium Jingles
PTM-09BK

The Primero Rock Tambourine features 6 double sets of Millennium Chrome Jingles in a matte black oval frame.



Headless Wood Tambourines
PTH-10B (Brass)

Brass is an alloy of copper and zinc and the jingles provide a bright mid-range tone.



Headless Wood Tambourines
PTH-10S (Stainless Steel)

Stainless Steel jingles produce a higher tone with extra top end and sustain.



Hi-Hat Jingle Ring
PJH-10SH

The Hi-Hat Jingle Ring has 20 sets of Stainless Steel tambourine style jingles that will accentuate your Hi-Hat sound with every opening and closing of your cymbals.



Gating Cabasa
CBS-100

Simply grab the precision handle and fire away to play any pattern you wish, or keep spinning it for an infinite "sizzle" that is not possible with standard Cabasas.

ASH TONE BLOCKS



Tang-Tang
PTG-20

A high and low pair of unique shakers that incorporate a Caxixi-Style Plate and Wooden "Clacker."



PAB-20 (High) **PAB-50 (Medium)** **PAB100 (Lo-w)**

Pearl's Ash Tone Blocks are constructed using Ashwood because it is extremely hard and durable. The Ash Tone Blocks are pitched in "thirds" and each block includes a mounting bracket that accepts a 3/8" post.

CLAVE BLOCKS



PBL-10 (High) **PBL-20 (Medium)** **PBL-30 (Low)**

Pearl's clave blocks are injection molded so they're virtually indestructible, and the solid color will never chip, fade, or peel. Our exclusive CDV (Chamber Density Variation) Technology process allows all three clave blocks to be the same dimensions but still differ in pitch.



PBL-100 Anarchy Block

Produces a low piercing pitch that will cut through even the heaviest metal rhythm section.



21" Field
Percussion Shaker
PGA-60FP

Hexagonal body and internal chamber for a truly massive sound.



Wood Hex Ganzas
PGA-30W (Short) **PGA-32W (Long)**

The wood Hex Ganzas are made from Shorea wood and maintain the same strong projection as their aluminum brothers, but deliver a warmer less metallic tone.



Hex Ganzas
PGA-30 (Short) **PGA-32 (Long)**

The Pearl aluminum Hex Ganzas give more sound control than round shakers and produce a lush shake sound due to their hexagonal shape.



Triple Shaker
PGA-40

6" long, rectangular aluminum shaker provides three unique sounds: shake, click, and swish.



Egg Carton
PEC-1

Three egg shakers in a clear tube that can be played separately or as a complete unit.

STANDS, BAGS, HOLDERS

Pro Tools for Every Gig

CONGA STANDS



Quick Release Double Conga Stand w/ Bag
PC-3000TW



Quick Release Double Conga Stand
PC-300W



Pro Conga Stand
PC-3000



All-Fit Conga Stand
PC-900



Primero Twin Conga Stand
PC-200



Ultra Lite Conga Stand
PC-2500



Primero Basket Conga Stands
PC-100P (10) PC-110P (11)

The **PC-3000TW** stand holds full size professional congas as securely as most stands double its weight and mass.

The **PC-300W** is scaled down to support our lighter Primero Conga lineup. Both stands setup in seconds because there are no wingnuts needed to mount your congas.

The **PC-2500** Ultralite Conga stand, is lightweight yet sturdy and stable. Index markings on all adjustable parts make for consistent lightning fast setups.

BONGO STANDS



Pro All Fit Bongo Stand with Spring Loaded Strap Hinge
PB-3000



Bongo Stand for Seated and Concert Player
PB-3000S



All-Fit Tilting Bongo Stand
PB-900LW



Lightweight Bongo Stand
PB-700



Bongo Attachment for PC200
PB-700BHS

DJEMBE STANDS



All Fit Djembe Stand
PC-800S



Pro Djembe Stand
PD-3000



All-Fit Djembe Stand
PC-800S

HEIGHT: 16" to 21"

CAJON STANDS



Cajon Stand
PC-J70STD

TRAP TABLES

Pearl's wide selection of trap tables and accessories feature sturdy and dependable options for any musical situation. Options include a variety of sizes, construction materials, tables with stands, tray tops and table tops only and single or double braced legs.

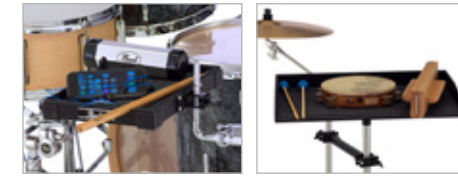

Trap Table Single Braced (18" x 24")
PTT-1824

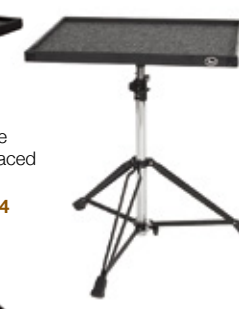

Trap Table Double Braced (18" x 24")
PTT-1824W



Aluminum Trap Table (15" x 24") w/o Stand
PTT-1524MPT



Tech Tray (8.5" x 11")
PTT-8511



Trap Table (12" x 12")
PTT-1212

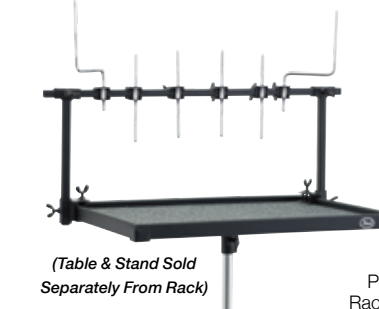

(Table & Stand Sold Separately From Rack)
Universal Trap Table Rack
PTR-UNV

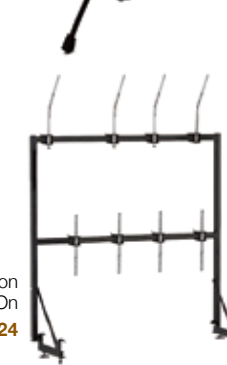

Percussion Rack Add On
PTR-1824



3/8" Straight Post
PTR-1824RC1



3/8" Angled Post
PTR-1824RC2



Post Attachment
PTR-1824RC6



(FOR PTT-1824, PTT-1212)
Trap Table Single Post Adapter
PTR-1824RC3

PERCUSSION CASES

Features include: ergonomic carrying straps, rubber protective bottoms, top-mounted carrying handles, tuning wrench pouches, & heavy duty double zippers.



12" Djembe Bag
PBJ-CXL



14" Djembe Bag
PBJ-CXXL



Box Cajon Case 13" x 14" x 20"
PSC-1213CJ



Travel Conga Case
PSC-1175TC

HOLDER & ACCESSORIES



Angled Post Adapter
PPS-37



Lug Mount Accessory Holder
PPS-40



Universal Guiro Holder
PGH-20



Foot Pedal Bracket
PPS-20



Cowbell Stacker
PCS-10



Stix-Free
PPS-10 & PPS-11



Percussion Toy Box (Accessories Not Included)
PTYB-1212

COWBELL HOLDERS



CA-130

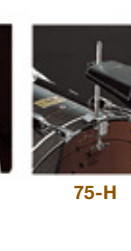

75-H



75-X



PPS-81



PPS-82

NOTE: Items pictured are not to scale

REPLACEMENT PARTS

MASKING COVERS & MOUNTING BRACKET

The GK-90 and BBC1 cover the holes of BT-3 and BB3 brackets that have been removed.



- BBC-1** For BB3, w/Gasket, Screws and Nuts
- GK-90** For BT3, inside/outside plates w/ Bolts
- BT-3** Tom Tom Bracket

BASS DRUM HOOP PROTECTORS



- HPP-2** Metal Hoop Protector for Wood BD Hoops
- NP-01** Hoop Protector for Metal BD Hoops
- NP-347/2** Non-Slip Hoop Protector for Wood BD Hoops (pair)

P2050 SERIES CAMS



ELIMINATOR OPTION CAM

- CAM-PL** Purple Cam, Aggressive Action
- CAM-YL** Yellow Cam, Inverse Action
- CAMT-BK** Translucent Black Cam, Linear Action
- CAMT-WT** Translucent White Cam, Oversized Linear Action
- CAMT-BL** Translucent Blue Cam, Progressive Action
- CAMT-RD** Translucent Red Cam, Radical Action

FLOOR TOM LEGS & BRACKETS

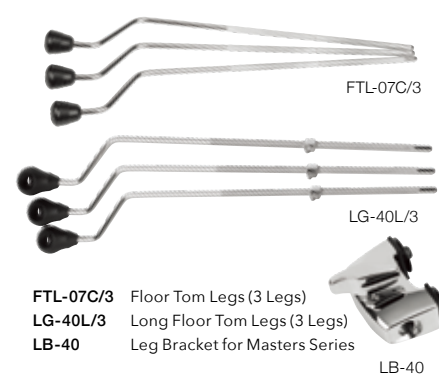

- FTL-07C/3** Floor Tom Legs (3 Legs)
- LG-40L/3** Long Floor Tom Legs (3 Legs)
- LB-40** Leg Bracket for Masters Series

HI-HAT CLUTCHES & PARTS

RAPID LOCK HI-HAT CLUTCHES

Hi-Hat set-up and tear-down is a breeze with Rapid-Lock's Patented* two-point quick release locking system. *U.S. Patent #9355625

- HCL-205DQR** Rapid Lock Quick Release Hi-Hat Drop Clutch w/ Locking Nut
- HCL-205QR** Rapid Lock Quick Release Super Grip Hi-Hat Clutch w/ Locking Nut
- HCL-105QR** Rapid Lock Quick Release Hi-Hat Clutch w/ Locking Nut
- HCL-79** Hi-Hat Clutch Complete
- HHC-90** Plastic Cup w/ Tilter



CHAINS & BELTS



- ME-805A** (Chain) P-830, 920, 922, 930, 932 Pedals
- ME-830A** (Chain) P-1030, 1032, 1030R, 1032R Pedals
- CCA-5** (Chain) P-2050C, 2052C Pedals
- CCA-5CF** (Chain) P-2050C/F Pedal
- CCA-300** (Chain) P-3000C, 3002C Pedals
- BCA-250** (Belt) P-2050B, 2052B Pedals

SPRING



- SP-64F** Spring for P-930, 932
- SP-64NFB** Spring for P-3000/3002, P-2050/2052

BEATERS & BEATER WEIGHTS



- DB-100** Duo-Beater Felt/Plastic
- B-250QB** Control Core Quadbeater
- B-350XR** X-Treme Impact Beater

BEATER WEIGHTS

- BW-100** Beater Weight, 3 Weights in One

MASTERCAST HOOPS

MasterCast are the finest die cast hoops available and feature the perfect blend of thickness and mass to improve the depth, clarity, and focus of toms and snare drums.



Model #	Diameter	# of Tension
DC-0805	8"	5
DC-1006	10"	6
DC-1206	12"	6
DC-1306	13"	6
DC-1308	13"	8
DC1308S	13"	8 Snare Side
DC-1408	14"	8
DC-1408S	14"	8 Snare Side
DC-1410	14"	10
DC-1410S	14"	10 Snare Side
DC-1410SG	14"	10 Snare Side w/ Guard
DC-1508	15"	8
DC-1608	16"	8
DC1808	18"	8

SUPERHOOP II

SuperHoop II hoops are precision formed from heavy-duty 2.3mm steel, triple-flanged and engraved with the SuperHoop II logo.



Model #	Diameter	# of Tension
SH-0604	6"	4
SH-0805	8"	5
SH-1006	10"	6
SH-1006S	10"	6 Snare Side
SH-1206	12"	6
SH-1208	12"	8
SH-1208S	12"	8 Snare Side
SH-1306	13"	6
SH-1308	13"	8
SH-1308S	13"	8 Snare Side
SH-1408	14"	8
SH-1408S	14"	8 Snare Side
SH-1410S	14"	10 Snare Side
SH-1410SG	14"	10 Snare Side w/Guard
SH-1608	16"	8
SH-1808	18"	8

STEEL HOOPS

Steel Hoop Model #	Diameter	# of Tension
RH-0804	8"	4
RH-1006	10"	6
RH-1206	12"	6
RH-1306	13"	6
RH-1408	14"	8
RH-1408S	14"	8 Snare side
RH-1608	16"	8
RH-1808	18"	8



BASS DRUM PEDAL TRAINING PAD

The BD10 bass pad is perfect for practicing at home or on the road. The wide pad accommodates double pedals and is specially formulated for extremely low noise and a realistic feel. The universal-fit "hoop" accepts all brands of pedals and adjusts to compensate for different floor surfaces. The BD-10 folds for compact transport.



- BD-10** Bass Drum Pedal Training Pad
- ZD-081A** Stop Lock Complete

QUICK RELEASE WINGLOC



- WL-230** Quick Release WingLoc
- WL-230A** Quick Release WingLoc Complete

SEAT CUPS AND FELTS



- RC-20** Reversible Seat Cup, w/ O-Ring
- PL-11** Cymbal Seat Cup
- FLW-001/2** Cymbal Felt Washer (2 Pieces)
- FLW-003** Hi-Hat Cup Felt Washer

DRUM KEYS



- KGT-100H** Gyro Tune Key w/ Quick Release
- K-030** Hi-Tension Tuning Key
- K-080** Tuning Key

AIR SUSPENSION FEET



- R-40/3** Air Suspension Rubber Feet (3 Each)
- R-5/3** Rubber Tip (3 Each)



RF ONE / MASTERS SHOWN WITH MASTERCAST HOOPS



PROFESSIONAL SERIES SHOWN WITH SuperHoop II HOOPS

LUGS

- CL-05** Lug for 3" Piccolo Snare
- CL-55** Lug for 5" & 5.5" Deep Snare
- CL-65** Lug for 6" & 6.5" Deep Snare
- CL-100** Lug for over 7" & 8" Deep Snare



REPLACEMENT PARTS

Pearl offers a tremendous number of parts for our drums and hardware. The parts represented on these pages are some of the most commonly requested items.

OPTI-LOC



OPL-1016/C

Opti-Loc suspension tom holders provide exceptional stability while greatly improving resonance and sustain. (For EXX / EXL Export / DMP)

- OPL-0608/C Opti-Loc for EXX and DMP 6"-8" Diameter
- OPL-1016/C Opti-Loc for EXX and DMP 10"-16" Diameter

R2 AIR & OPTIMOUNT

To attain tonally true sound, every drum would have to be mounted in a floating point at the center of its shell. R2 Air equally balances mounting pressure across two floating points at the top and bottom of each tom. This gives true tonal separation from mounting hardware and enhances sonic output. U.S. Patent #11640814



R2AS-10-0708C



JUNGLE GIG



JG-16

JG-16 • Pearl's Jungle Gig allows the conversion of a 16" Floor Tom to a Bass drum.



Our OptiMount Suspension System attaches to the tom's tension rods and floats on rubber cushions, providing the ultimate in stability while allowing the drum to resonate fully without restriction.



OPT-0708 OPT-0910 OPT-1112



OPT-1314 OPT-1516

- OPT-0708 / for drums 7"-8" deep, 8"-16" diameter
- OPT-0910 / for drums 9"-10" deep, 8"-16" diameter
- OPT-1112 / for drums 11"-12" deep, 8"-16" diameter
- OPT-1314 / for drums 13"-14" deep, 8"-16" diameter
- OPT-1516 / for drums 15"-16" deep, 8"-16" diameter

ULTRA-SOUND SNARES

Pearl's Ultra-Sound snares feature patented Graduated Tension wires for extended dynamic range from ultra soft to ultra loud. Ultra-thin, low mass end plates assure ultra quick response. The end plates feature three mounting options: tunnels or holes for cord mounting and slots for straps. U.S. Patent #7202405

20 / I 20 / D 20 / C



- SN-1320C 20 strands for 13", C-type, w/ straps & cords
- SN-1320D 20 strands for 13", D-type, w/ straps & cords
- SN-1320I 20 strands for 13", I-type, w/ straps & cords
- SN-1420C 20 strands for 14", C-type, w/ straps & cords
- SN-1420D 20 strands for 14", D-type, w/ straps & cords
- SN-1420I 20 strands for 14", I-type, w/ straps & cords

42 / I 42 / D 42 / C



- SN-1442C 42 strands for 14", C-type, w/ straps & cords
- SN-1442D 42 strands for 14", D-type, w/ straps & cords
- SN-1442I 42 strands for 14", I-type, w/ straps & cords

STRAINERS



SR-017

- SR-014N Standard Snare Strainer
- SR-017 Snare Strainer Complete
- SR-018 Snare Strainer Complete

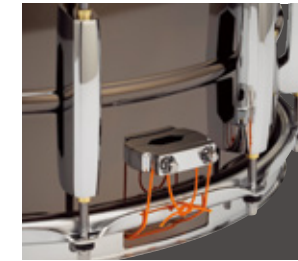

ON



OFF

THE SR-017 STRAINER Simple and effective, the SR-017 is a Pearl standard for effortless snare switching and sensitivity control. Its smooth lever action and fine-tuning knob let you dial in the right amount of snare wire saturation to suit your personal sound.

REPLACEMENT SNARES



SPS-18/6
SNC-500R/4

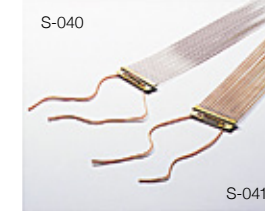

S-040

S-041

- S-022N 20 Strand for 14" w/ Cords
- S-022NU 20 Strand for 14" w/ Cords, Uncoated
- S-022 20 Strand for 14" w/ Straps
- S-025 20 Strand for 14" long, w/ Straps
- S-029N 20 Strand for 13" w/ Cords
- S-030N 24 Strand for 14" w/ Cords
- S-031N 20 Strand for 12" w/ Cords
- S-032N 16 Strand for 10" w/ Cords
- S-033N 16 Strand for 12" w/ Cords
- S-040 15 Strand for 14" w/ Cords, Steel Cable, Thinner Gauge
- S-041 15 Strand for 14" w/ Cords, Bronze Cable, Thicker Gauge
- SPS-18/6 Plastic Strap (6/pkg)
- SNC-500R/4 Snare Cord (4/pkg)

STAINLESS STEEL TENSION RODS

Pearl's Stainless Steel Tension Rods are machined, not forged, from a single piece of stainless steel to the most exacting tolerances in the industry. They feature super-smooth, precise tensioning, with absolutely no play. Each non-plated stainless steel tension rod is matched with a precision-machined brass swivel nut for ultra-precise performance.



- SST-5028/6 W7/32 x 28mm (6)
- SST-5035/6 W7/32 x 35mm (6)
- SST-5038/6 W7/32 x 38mm (6)
- SST-5042/6 W7/32 x 42mm (6)
- SST-5047/6 W7/32 x 47mm (6)
- SST-5052/6 W7/32 x 52mm (6)
- SST-6115 M6 x 115mm

MUFFLERS

External clamp-on muffler for snare drums and toms. By adjusting the pressure and position of the felt pad, excessive overtones can be precisely controlled or eliminated.



OM-1

- OM-1 Clamp-on Muffler, Snare Drum & Toms

MUFFLE HEADS

Model #	Size	Model #	Size
MFH-08	8"	MFH-14	14"
MFH-10	10"	MFH-16	16"
MFH-12	12"	MFH-20B	20"
MFH-13	13"	MFH-22B	22"

BASS DRUM MUFFLER



BDM-F

BDM-M

- BDM-F Bass Drum Muffer (Full Size)
- BDM-M Bass Drum Muffer (Mini Size)

TENSION ROD LOCKNUTS



TNK-10N/10

TL-20/10

- TNK1-0N/10 Tension Keeper (10/pkg)
- TL-20/10 Tension Rod Lock Nuts (10/pkg)

TENSION ROD WASHERS



NLW-12B/12

MTW-12/12

- NLW-12B/12 Nylon Washers (12) Black
- MTW-12/12 Metal Washers (12)

TENSION RODS

- T-055/6 W7/32 x 28mm (6) for 3" Deep Snare
- T-060/6 W7/32 x 35mm (6) for Free Floaters before 2002
- T-061/6 W7/32 x 42mm (6)
- T-061L/6 W7/32 x 47mm (6) for 6.5" Deep Snare
- T-062/6 W7/32 x 52mm (6) for 5.5" Deep Snare
- T-065 M6 x 90mm (Bass Drum)
- T-066 M6 x 115mm (Bass Drum)
- TR-5052 W7/32 x 52mm (DMP, EXL, EXX, MDT Snare)
- TR-5047 W7/32 x 47mm (DMP, EXL, EXX, MDT Toms)
- TR-5100 W7/32 x 100mm (Bass Drum)



T-055/6



T-060/6



T-061/6



T-061L/6



T-062/6



T-065



T-066



AARON SMITH
Independent
ADAM "SMILEY" WADE
Dua Lipa
ADAM JANZI
VOLA
ADAM TUMINARO
OrlandoDrummer
ALEX HOLZWARTH
Tarja Turunen/Turilli-Lione Rhapsody

DANI LÖBLE
Helloween
DANIEL ERLANDSSON
Arch Enemy
DAVID CARDONA
TheCityIsOurs
DAVID FRIEDRICH
Electric Callboy
DENNIS CHAMBERS
Drumming Legend



ALFREDO GOLINO
Independent
ANDREA POLIDORI
Independent
ANDREW TKACZYK
The Ghost Inside
AREJAY HALE
Halestorm
ARIEN VAN WEESENBEEK
Epica

DEXTER HERCULES
Ed Sheeran
DIRK BRAND
Axxis / Subsignal / Independent
ELISE TROUW
Independent
ERIC SINGER
KISS
FLAVIO MEZZODI
Krokus / Gotthard



BAARD KOLSTAD
Leprous / Rendezvous Point
BARRY KERCH
Shinedown
BEN GORDON
Parkway Drive
BEN JOHNSTON
Biffy Clyro
BILLY HART
Jazz Legend

FLO MOUNIER
Cryptopsy
FLORENT MARCADET
Carpenter Brut
GABE HELGUERA
I Prevail
GABOR DORNYEI
Independent
GARY HUSBAND
Independent



BORIS LE GAL
Betraying The Martyrs / Dropdead Chaos
BRANDON PERTZBORN
The Offspring
BRIAN FRASIER-MOORE
PINK
BRUNO VALVERDE
Angra / Independent
CALVIN RODGERS
Independent

GENE HOGLAN
Dark Angel / Death To All
GEORGE KOLLIAS
Nile
GREG HUTCHINSON
Independent
GREYSON NEKRUTMAN
Sepultura
HORACIO HERNÁNDEZ
Latin Legend



CASEY COOPER
@COOP3DRUMM3R
CESAR ZUNDERWIJK
Golden Earring / Sloper
CHRISTOPHER WILLIAMS
Accept
CORRADO BERTONAZZI
Independent
DAN PRESLAND
Ne Obliviscaris

IAN PAICE
Deep Purple
INFERNO
Behemoth
ISAC JAMBA
Independent
JAMIE WESTLAND
Di-rect
JAN-VINCENT VELAZCO
Pendragon / Esprit D'Air / Independent



JASON BOWLD
Bullet For My Valentine



JEN LEDGER
Skillet / Ledger



JERMAINE WHYTE
Rita Ora / Emeli Sandé/
Mabel / Boy George



JESSE J GRANT
Gabrielle/Independent



JOCKE WALLGREN
Amon Amarth



MIKE WENGRN
Disturbed



MORITZ MÜLLER
The Intersphere / Helene Fischer



NORMAN BONINK
BLØF



OMAR HAKIM
Independent



PETE YORK
Super Drumming / Independent



JOEY JORDISON
In Memoriam



JOHN LONGSTRETH
Origin



JON LARSEN
Volbeat



JOSH MCKNASTY
Independent



JUSSI 69
The 69 Eyes

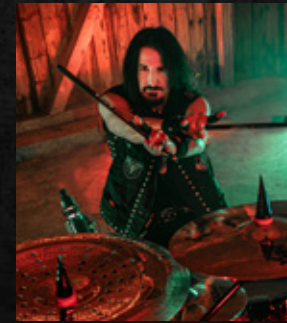

RANDY BLACK
Destruction



RAPHAEL MERCIER
Mass Hysteria / Tagada Jones



RAY LUZIER
Korn



RICCARDO MERLINI
Independent



RICK VAN WORT
Antoon / Nielson / Sera



KAI HAHTO
Nightwish



KATHA MIA
Mono Inc.



LINA ANDERBERG
Zara Larsson



LUCAS VAN MERWIJK
Drums United



MANU REYES
Söber



RICKY LEWIS
The Weeknd



ROEL VAN HELDEN
Powerwolf



SERGIO PESCARA
Independent



SHANNON FORREST
Toto



TARON LOCKETT
Cory Henry And The Funk Apostles



MARTIN "MARTHUS" SKAROUPKA
Cradle of Filth



MATT HALPERN
Periphery



MATT MCGUIRE
The Chainsmokers



MAURICIO WEIMAR
Extreme Drums



MICHELLE BAPTISTE
Lizzo



TODD SUCHERMAN
Styx



TONY PALERMO
Papa Roach



TROY WRIGHT
Independent



TOSH PETERSON
Damnage, Troye Sivan



TRYM
Emperor



MICKY MARTINEZ
Independent



MIGUEL LAMAS
Dani Martín/Independent



MIKE COOLEN
Within Temptation



MIKE MANGINI
Independent



MIKE MILEY
Rival Sons



WALTERI VÄYRYNEN
Opeth



WILL HUNT
Evanescence



WILL KENNEDY
Yellowjackets / Jazz Legend



YORAN VROOM
Independent



ZACKY
Independent

COLOR & CONFIGURATION CHART

P Premium Finish **C** Custom Finish

REFERENCE ONE THE REFERENCE LEGACY... UNLEASHED.

PAGES 11 - 12

	RF1924XSP	RF1904XP	RF1943XP	RF1923XDP	RF1983XP

MASTERS MAPLE GUM THE EVOLUTION OF PREMIUM STUDIO TONE.

PAGES 15 - 16

	MMG924XSP	MMG904XP	MMG943XP	MMG923XDP	MMG983XP

MASTERS MAPLE SONICALLY CENTERED, ARTICULATE, AND POWERFUL.

PAGES 17 - 18

	MM6924XSP	MM6904XP	MM6943XP	MM6923XDP	MM6983XP

MASTERS MAPLE PURE BRIDGING THE GAP BETWEEN STUDIO AND STAGE.

PAGES 19 - 20

	MP4924XSP	MP4904XP	MP4943XP	MP4923XDP	MP4983XP

COLOR & CONFIGURATION CHART

PROFESSIONAL SERIES AN UPDATED, UPGRADED, PREMIUM GIGGING POWERHOUSE.

PAGES 21 - 22

	PMX904XP/C	PMX923XDP/C	PMX924XSP/C	PMX925XSP/C	RF1943XP/C

SESSION STUDIO SELECT AN ALL MAPLE DRUM SHELL FIT FOR THE MASTERS LEGACY.

PAGES 23 - 24

	STS983XP/C	STS904XP/C	STS924XSP/C	STS925XSP/C	STS943XP/C

PRESIDENT SERIES DELUXE A MODERN REVIVAL OF THE DARKLY UNIQUE LAUAN SOUND.

PAGES 25 - 26

	PSD903XP/C	PSD904XP	PSD923XP/C	PSD924XP	PSD943XP/C

COLOR & CONFIGURATION CHART

CRYSTAL BEAT THE ORIGINAL SEAMLESS ACRYLIC DRUM SHELL.

PAGES 27 - 28



#730 Ultra Clear

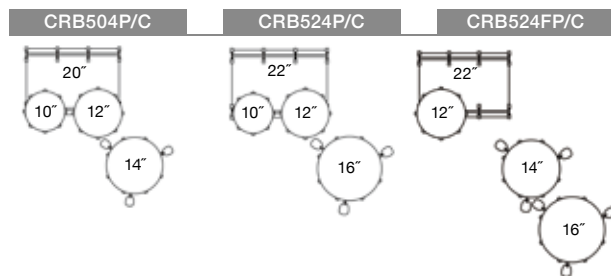

DECADE MAPLE A DRUM KIT 10 YEARS IN THE MAKING.

PAGES 29 - 30



#207 Ultramarine Velvet #227 Satin Slate Black



#260 Satin Brown Burst #262 Satin Black Burst



#884 Ice Mint

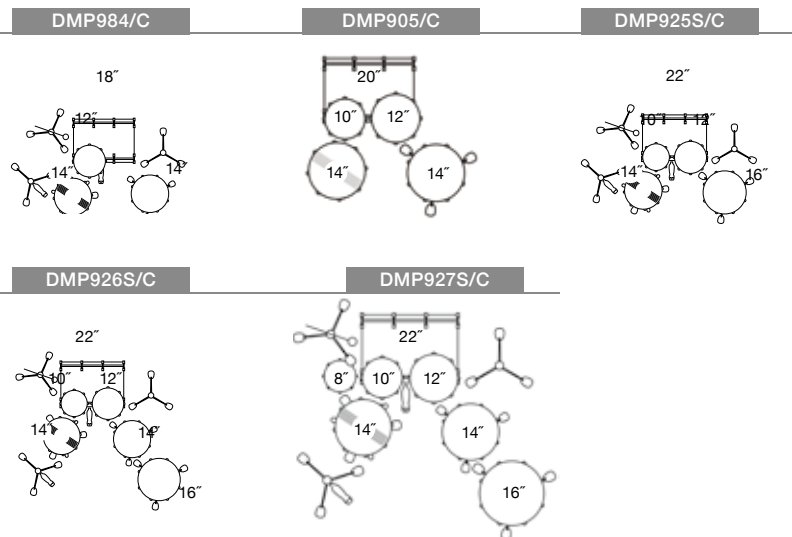

EXPORT THE BEST SELLING DRUM SET OF ALL TIME.

PAGES 31 - 32



#31 Jet Black #704 Black Cherry Glitter



#717 High Voltage Blue #735 Satin White



#777 Slipstream White #778 Graphite Silver Twist



#779 Metallic Amethyst Twist

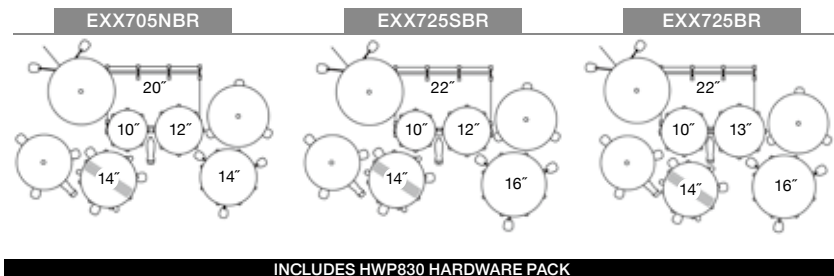

INCLUDES HWP830 HARDWARE PACK

COLOR & CONFIGURATION CHART

MIDTOWN BIG GIG, SMALL RIG, HUGE SOUND.

PAGES 33

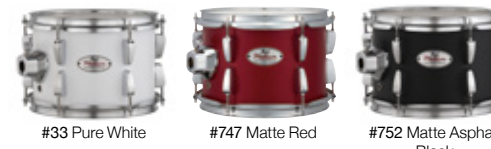

#33 Pure White #747 Matte Red #752 Matte Asphalt Black

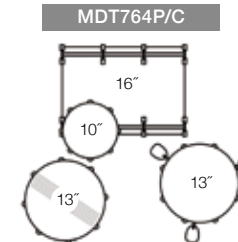

ROADSHOW IT'S YOUR TIME TO PLAY, START THE RIGHT WAY.

PAGES 34



#31 Jet Black #707 Bronze Metallic



#743 Royal Blue Metallic #747 Matte Red

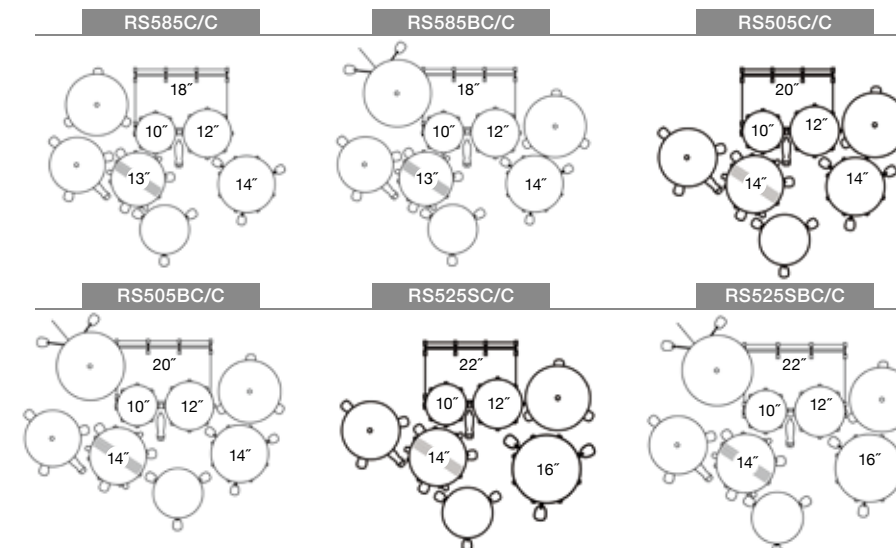

INCLUDES CH50/H50/S50/P50/D50/16\"/>

ROADSHOW JR. COMPLETE WITH HARDWARE, CYMBALS, AND THRONE FOR DRUMMERS UNDER 8.

PAGES 34



#31 Jet Black #708 Grindstone Sparkle

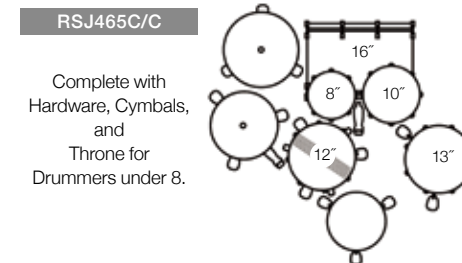

Complete with Hardware, Cymbals, and Throne for Drummers under 8.



THE BEST WARRANTY IN THE INDUSTRY!*

COMMITTED TO THE HIGHEST LEVEL OF CUSTOMER SATISFACTION.

The Pearl Lifetime Warranty is our pledge to you that we will proudly stand behind our high-end product for as long as you own it. Pearl drums are designed and manufactured to the highest standards in quality, style, appearance and playing performance. This Lifetime Warranty for Pearl's new high-end drums reflects a tradition of excellence and a commitment to superior engineering and craftsmanship dedicated to you, the drummer.

This warranty is applicable to the following series: Masterworks, Reference One, Masters Maple Pure, Masters Maple, purchased from May 26th 2023, and applies to the European Economic Area only.

BUY IT ONCE, PLAY IT FOR LIFE.



SPECIAL ORDER LACQUER FINISHES

[PREMIUM]



#100 Wine Red



#103 Piano Black



#111 Matte Natural



#124 Matte Black Mist



#201 Matte Walnut
(Maple)



#310 Brooklyn Burst



#353 Matte White



#359 Twilight Burst



#831 Matte Olive Burst



#844 Satin Rose Gold



#859 Putty Grey



#886 Deep Redburst

[CUSTOM]



#195 Crystal Rain



#198 Shimmer of OZ



#376 Ultra Blue Fade



#400 White Marine
Pearl



#414 Ice Blue Oyster



#415 Bronze Oyster



#418 Blue Abalone



#422 Matte White
Marine Pearl



#453 Platinum Gold
Oyster



#736 Turquoise Pearl



#824 Satin Charred Oak



#839 Red Burst Triband



#843 Osiria Rose Stripe



#850 Aqua Turquoise
Stripe



#855 Black Oyster Swirl



#856 Red Oyster Swirl



#857 Sunburst Red-
stripe



#858 Kobalt Blue Fade
Metallic



#885 Cherry Amber
Fade

Pearl Music Europe B.V.

Craenakker 28 NL-5951 CC Belfeld, The Netherlands
Pearl Music Europe B.V., P.O. Box 1078 NL-5900 BB Venlo, The Netherlands

WWW.PEARLDRUM.COM

